

S.C.O.T.T F.U.L.L.E.R  
R.E.P.R.O.D.U.C.T.I.O.N.S

*Specializing in Quality, Hard-to-Find 1965 – 1970  
Shelby, Boss, and Mustang Reproduction Parts*



# Welcome to Scott Fuller Reproductions

We Specialize in Quality, Hard-to-Find 1965 - 1970  
Shelby, Boss, and Mustang Reproduction Parts

## My Mission:

To provide the Shelby, Boss, and Mustang restorer and hobbyist with the highest quality, most accurate, reproduction parts available anywhere.

If it isn't an accurate, high quality reproduction of the original assembly line part, you won't find it here. Every part you see here was been painstakingly researched to guarantee its accuracy.

Many of the items offered here are only available through Scott Fuller Reproductions and my website, and are not available anywhere else.

Hopefully I have an item that you have been looking for.

Please have a look around.

I am in the process of adding new items just as fast as I can get them fabricated. Please check my website often for the status of new items.

Items that are new to this catalog are marked as "New Items". Future items are also identified and have my "best guess" at an expected completion date.

Many of the items in the catalog are very limited quantities. Please keep that in mind when ordering. They may not be available in the future.

Thanks,

Scott Fuller

# Table of Contents

New Catalog Items ..... NP1 - NP8

Main Catalog..... 1-16

## Exhaust

H-pipes.....	1, 2, 3
Intermediate Pipes/Main Pipes .....	3, 4
Mufflers.....	7, 8
Tailpipes.....	5, 6
Tips.....	6, 8
Clamps and Hangers.....	10, 11
Donuts.....	14

## Suspension

Tie Rod End Boots.....	14
Sway Bar Brackets.....	9

## Electrical

Starter Delay.....	1, 15
Dynamite Sticks.....	1, 15

## Plastic Parts

Wiring Clips.....	13, 16
Tilt Column Pin.....	13

## Trunk

J-Bolts.....	12
Wing Nuts.....	13
Hold Down Plate.....	10

## Miscellaneous

Convertible Floor Pan Plugs.....	9
Starter Delay Parts Pkg.....	15
Dynamite Stick Install Kit.....	15
SFR T-Shirts.....	16
Boss 429 Lug Nuts.....	11

Reference Information..... R1-R6

Exhaust Supplement (Exhaust by Application).....S1-S14

Contact Information and Ordering..... inside back cover

# *New Products*

Made Exclusively by

S.C.O.T.T  
F.U.L.L.E.R  
R.E.P.R.O.D.U.C.T.I.O.N.S

And

Only Available at  
[www.ScottFullerReproductions.com](http://www.ScottFullerReproductions.com)



These Products are New  
to the 2011 Catalog

## 1967 Shelby GT-500 and GT-350 Tailpipe Tips (Early Production Variant)

Part Number  
**EX-TIP2**



Above - Pair of New Two-Piece Reproduction Shelby Tips  
Every feature of the original tip is faithfully copied:

- Correct body contour and weld
- All dimensions same as original tip
- Two slots in pipe at inlet
- Unfinished ends...just like the original
- Factory chrome finish
- S7MS part number stamped in tip

Concours perfect reproduction of the two-piece exhaust tips used on 1967 Shelby GT-500s and GT-350s. This two-piece welded tip was used on Shelybs with car numbers starting before about 1600, however the exact cutoff date is not known.

*Indistinguishable from the originals*



Above - Original and New Reproduction Tip



Above - S7MS Part Number Stamped in Original Tip



Above - S7MS Part Number Stamped in New Tip



Above - New Tip Features

**The price is \$325/pair + shipping**

Visit our website at [www.ScottFullerReproductions.com](http://www.ScottFullerReproductions.com)

Email us at [sfreproductions@aol.com](mailto:sfreproductions@aol.com) with any questions or for your order

**Note:** The concours correct tailpipe/tip horseshoe clamps are also available for \$14/each



## 1967 Shelby GT-500 and GT-350 Tailpipe Tips (Late Production Variant)

Concours perfect reproduction of the one-piece exhaust tips used on 1967 Shelby GT-500s and GT-350s. This one-piece formed tip was used on Shelybs with car numbers starting after about 1600, however the exact cutoff date for the early variant and the one-piece variant is not known.

*Indistinguishable from the originals*



Above - Pair of New One-Piece Reproduction Shelby Tips

Every feature of the original tip is faithfully copied:

- Correct body contour
- All dimensions same as original tip
- Two slots in pipe at inlet
- Unfinished ends...just like the original
- Factory chrome finish



Above - Original NOS Tip (top) & New Reproduction (bottom)

**The price is \$325/pair + shipping**

Visit our website at [www.ScottFullerReproductions.com](http://www.ScottFullerReproductions.com)

Email us at [sfreproductions@aol.com](mailto:sfreproductions@aol.com) with any questions or for your order

**Note:** The concours correct tailpipe/tip horseshoe clamps are also available for \$14/each



Above - Slotted End of Tip (inlet)



## 1968 Shelby GT-500 and GT-350 Tailpipe Tips

Part Number  
**EX-TIP3**



Above - Pair of New Reproduction 1968 Shelby Tips

Every feature of the original tip is faithfully copied:

- Correct body contour
- All dimensions same as original tip
- Two slots in pipe at inlet
- S8MS part number stamped in tip
- Factory chrome finish

Perfect reproduction of the pipe-within-a-pipe exhaust tips used on 1968 Shelby GT-500s and GT-350s. Correct spot welded construction with painted black-out...just like the originals. Shelby engineering drawings and original assembly line tips were used to design and verify the tooling used to make these tips.

**Indistinguishable from the originals**



Above - New Reproduction Tips



Above - S8MS Part Number Stamped in New Tip



Above - Top is New Tip, Bottom is Original Tip



Above - S8MS Part Number Stamped in Original Tip

**The price is \$375/pair + shipping**

Visit our website at [www.ScottFullerReproductions.com](http://www.ScottFullerReproductions.com)

Email us at [sfreproductions@aol.com](mailto:sfreproductions@aol.com) with any questions or for your order

**Note:** The concours correct tailpipe/tip horseshoe clamps are also available for \$14/each



# 1967 Shelby GT-500, Shelby GT-350, and Mustang GT Transverse Muffler

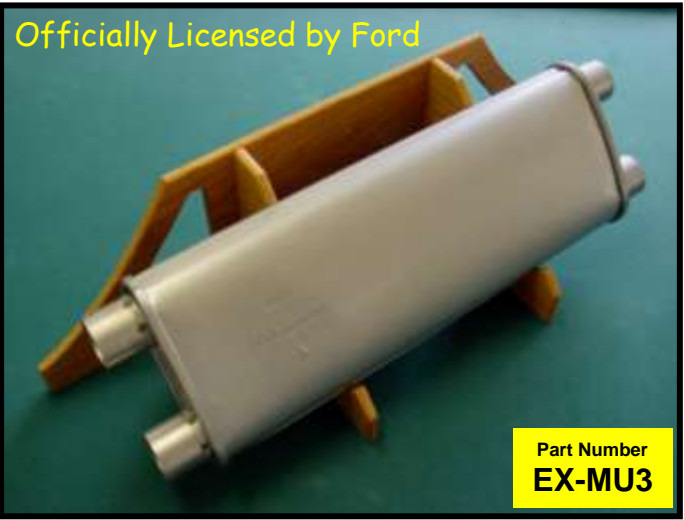

- Exact duplicate of the transverse muffler used on:
- 1967 Shelby GT-500 and GT-350
  - 1967 Mustang GT w/289 HiPo
  - 1967 Mustang GT w/390

Correct and accurate in every detail. All features of the new muffler were taken from original Ford 1967 assembly line mufflers and vintage Ford engineering drawings...no guesswork here.

Three date codes to choose from - 8/66, 12/66, & 1/67

## Muffler Features

- Same overall dimensions and shape as the original Ford mufflers
- Same aluminized material as the originals
- 100% accurate stamping of the FoMoCo logo, part number, and date (3-to choose from)
- Extruded inlet and outlet pipes
- Notches in the inlet pipes...just like the originals
- Seam and "Hump" in outer casing exactly like the original mufflers

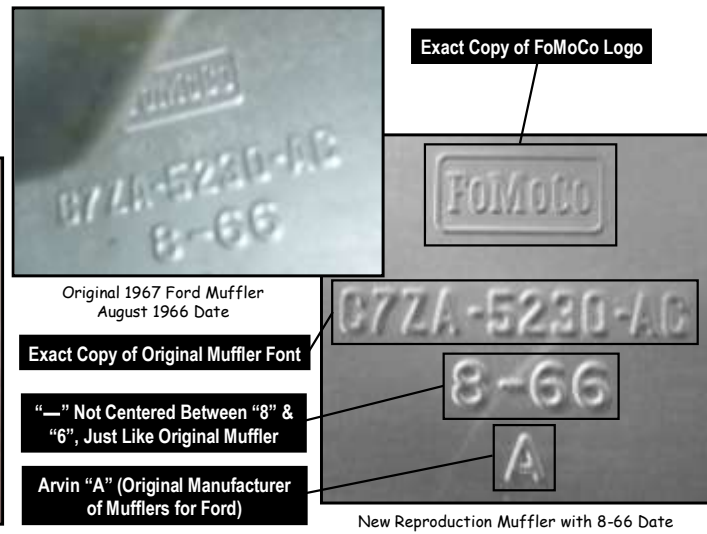
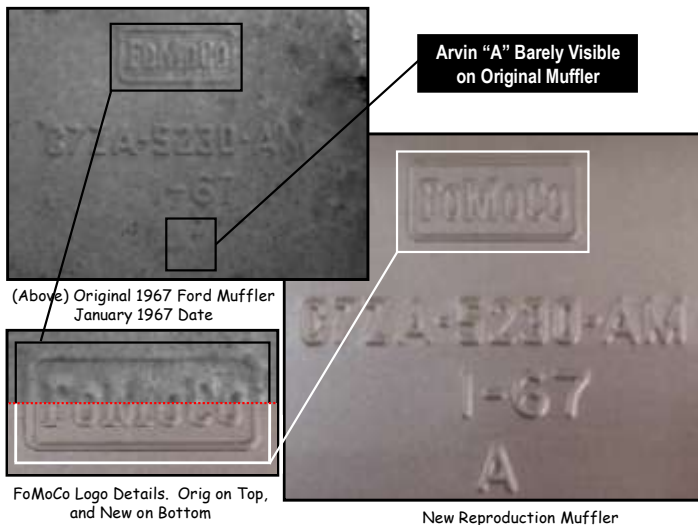
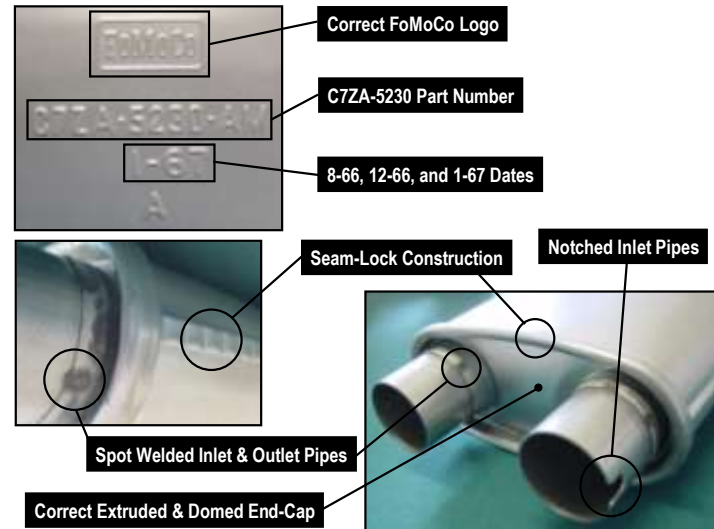

**The price is \$675 + shipping**

Visit our website at [www.ScottFullerReproductions.com](http://www.ScottFullerReproductions.com)

Email us at [sfreproductions@aol.com](mailto:sfreproductions@aol.com) with any questions or for your order



# 1968 Shelby GT-500, Shelby GT-350, and Mustang GT Transverse Muffler

Exact duplicate of the transverse muffler used on:

- 1968 Shelby GT-500 and GT-350
- 1968 Mustang GT w/302
- 1968 Mustang GT w/390

Correct and accurate in every detail. All features of the new muffler were taken from original Ford 1967 assembly line mufflers and vintage Ford engineering drawings...no guesswork here.

Four date codes to choose from - 8/67, 12/67, 3/68, and 5/68

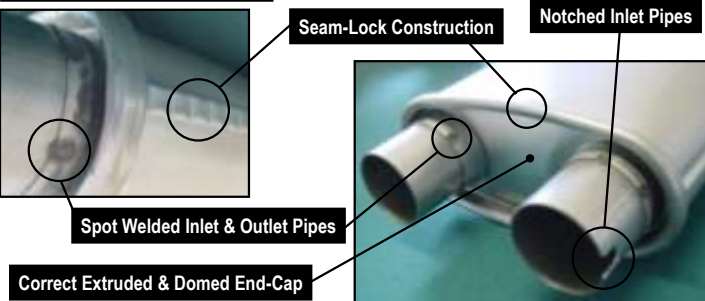
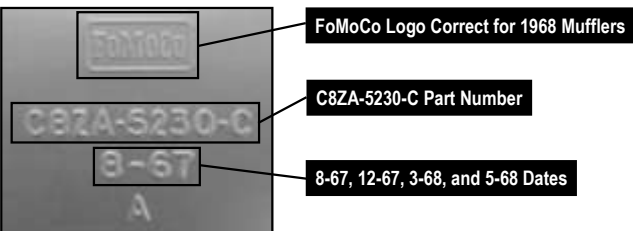

## Muffler Features

- Same overall dimensions and shape as the original Ford mufflers
- Same aluminized material as the originals
- 100% accurate stamping of the FoMoCo logo, part number, and date (4-to choose from)
- Extruded inlet and outlet pipes
- Notches in the inlet pipes...just like the originals
- Seam and "Hump" in outer casing exactly like the original mufflers

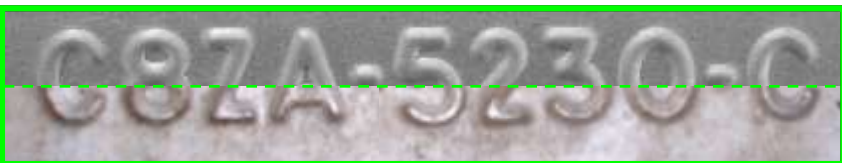

Above Top - New Muffler Stamping, Bottom - Original Muffler Stamping



Above - New FoMoCo Stamping

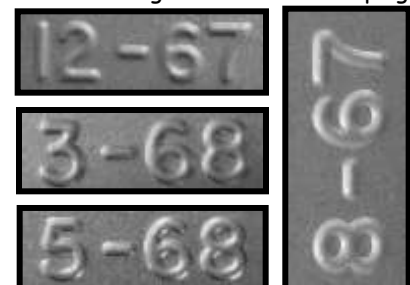

Above - Available Date Codes

Above - Original 1968 Muffler Stamping

**The price is \$675 + shipping**

Visit our website at [www.ScottFullerReproductions.com](http://www.ScottFullerReproductions.com)

Email us at [sfreproductions@aol.com](mailto:sfreproductions@aol.com) with any questions or for your order



# 1969 Boss 429 Lug Nuts

(Very Limited Supply)

**First time ever offered – Now Available**



Above - Original Lug Nut (L) and 3-New Lug Nuts (R)

These lug nuts were originally installed at the Kar Kraft facility when the cars were assembled for Ford. The lug nuts were never assigned a Ford part number and were never serviced by Ford, which contributes to their rarity. Once the original lug nuts were damaged or ruined, there was no source for replacing them...until now.

Concours exact reproduction of the stainless capped lug nut used on 1969 Boss 429s. Deep drawn stainless steel formed cap with encapsulated hex nut. Made entirely from scratch to exactly match the original lug nuts installed on the assembly line by Kar Kraft.



Above - New Reproduction Boss 429 Lug Nuts



Above - New Lug Nut Fabrication Sequence



Above - Jeremy Feller's (Carmel, Indiana) 1969 Boss 429 Sporting New Scott Fuller Reproduction Lug Nuts

**The price is \$385/car set + shipping**

Visit our website at [www.ScottFullerReproductions.com](http://www.ScottFullerReproductions.com)

Email us at [sfreproductions@aol.com](mailto:sfreproductions@aol.com) with any questions or for your order

Note: Not available individually, only sold in quantities of 20-pieces



# 1968 Shelby Console Weather-Stripping

**First time ever offered – Now Available**

Part Number  
**MS-WS1**



Above - Shelby Console w/Weather-Stripping

Exactly like the original. Copied from an original console part. The reproduction is the same sponge rubber material as the original and has been extruded through a die of correct contour to produce a new piece of weather-stripping.

Concours correct reproduction of the unique weather-stripping located at the top of all 1968 Shelby consoles. Correct for GT-350, GT-500, and GT500KR.

Not some off-the-shelf piece that is close to the original, but a custom made piece of new weather-stripping that matches the material and contour of the original piece.

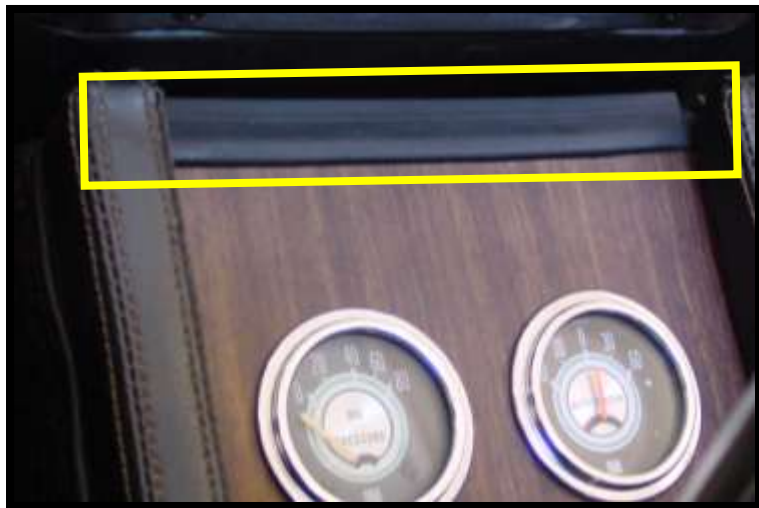

Above - Shelby Console w/Weather-Stripping



Above - Original on Left & New on Right



Above - Original on Left & New on Right

**The price is \$35/each + shipping**

Visit our website at [www.ScottFullerReproductions.com](http://www.ScottFullerReproductions.com)

Email us at [sfreproductions@aol.com](mailto:sfreproductions@aol.com) with any questions or for your order



# 1968 Front Wiring Harness Shield (Air Conditioned Cars)

**First time ever offered – Now Available**

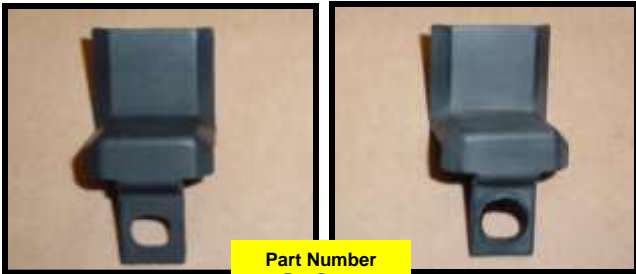

Part Number  
**MS-CLP3**



Concours exact reproduction of the unique plastic shield used on all 1968 Mustangs and Shelbys with air conditioning. Never before reproduced.

Attaches behind the two lower A/C condenser mounting screws. Two shields required per car.

Above - New Shield on Left & Original on Right

This plastic part is frequently missing, damaged, faded from heat, brittle, or broken. Used shields are extremely hard to find in usable condition. The new shields are exactly like the originals and ready to install.

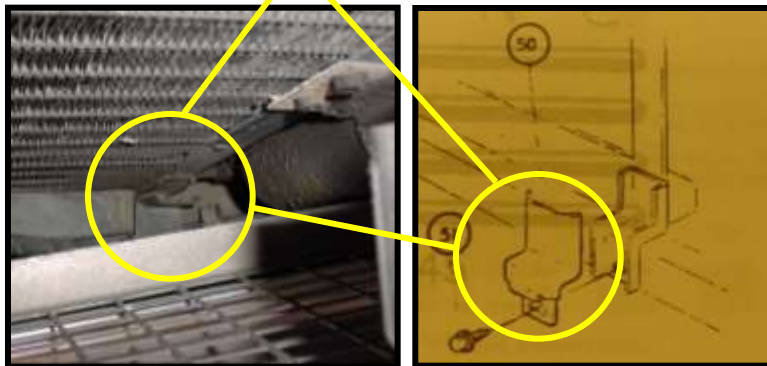
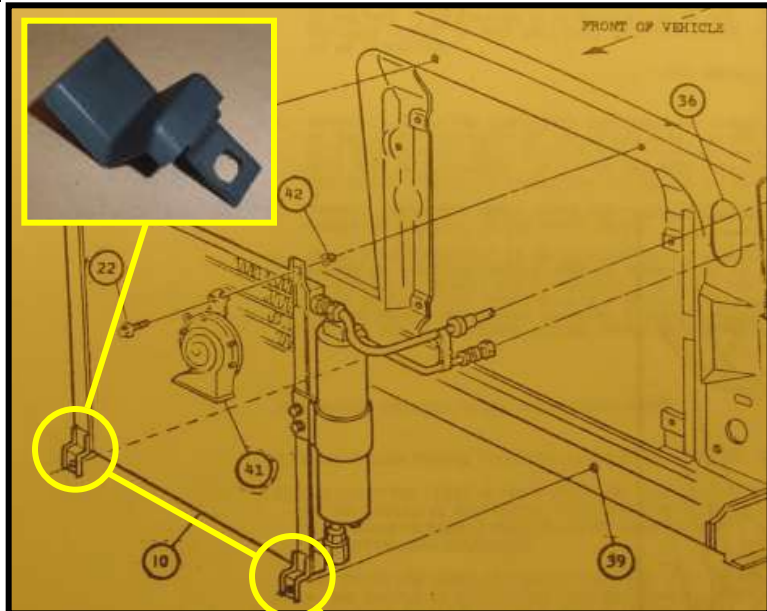

Above - New Shield on Left & Original on Right

Above - Mounting Location of Plastic Shield

**The price is \$50/pair + shipping** (enough for one car)

Visit our website at [www.ScottFullerReproductions.com](http://www.ScottFullerReproductions.com)

Email us at [sfreproductions@aol.com](mailto:sfreproductions@aol.com) with any questions or for your order



# *Main Catalog Products & Parts*

Made Exclusively by

S.C.O.T.T  
F.U.L.L.E.R  
R.E.P.R.O.D.U.C.T.I.O.N.S

And

Only Available at  
[www.ScottFullerReproductions.com](http://www.ScottFullerReproductions.com)



## Shelby, Boss, & Mustang Items for Sale Spring 2011

### 1968½ Shelby GT500KR and Mustang Starter Delay - \$1,485/each

Part Number  
**EL-SR1**



100% functional, exact copy of the original production line starter delay used on every 1968½ 428 Cobra Jet powered Shelby GT500KR and Mustang. No corners have been cut in components, materials, fabrication, or functionality. Every component was custom made to exactly match the original production line starter delays.

### 1968 Shelby Mustang Sequential Taillight Dynamite Sticks - \$295/pair

Part Number  
**EL-DS1**



Correct for 1968 GT-350, GT-500, and GT500KR Shelby Mustangs. Completely electrically functional, correct size and length paper tubes, correct wire size, length, and color, and correct plug. 100% accurate stamping. Four dates are available; December 1967, March 1968, June 1968, and July 1968 dated sticks.

### 1969/1970 Boss 429 H-Pipe - \$475/each

Part Number  
**EX-HP4**



Concours correct H-pipe for 1969 and 1970 Boss 429 Mustangs. Guaranteed to fit. 100% accurate bends with all factory flats and stop tabs. Correct cross-over tube, heat riser tube, and flanges. Available in aluminized or bare steel (add \$50 for bare steel).

### 1969/1970 Boss 302 H-Pipe - \$555/each

Part Number  
**EX-HP5**



Concours correct H-pipe for 1969 and 1970 Boss 302 Mustangs. Guaranteed to fit just like the originals. 100% accurate bends with all factory flats and alignment tabs. Correct cross-over tube and flanges. Available in aluminized or bare steel (add \$50 for bare steel).

## Shelby, Boss, & Mustang Items for Sale Spring 2011

### 1968 Shelby GT-350 and 1968 302 GT H-Pipe - \$465/each

Part Number  
**EX-HP7**



100% accurate reproduction of the H-pipe used on 1968 Shelby GT-350s and 1968 Mustangs with 302 engines and dual exhaust. 100% accurate bends with all factory flats and tabs. Available in aluminized or bare steel (add \$50 for bare steel).

### 1968½/1969 428 CJ/SCJ H-Pipe - \$465/each

Part Number  
**EX-HP3**



Concours correct H-pipe for 1968½ and 1969 CJ/SCJ Mustangs (inc GT500KR). Guaranteed to fit just like the originals. 100% accurate bends with all factory flats and stop tabs. Correct cross-over tube and flanges. Available in aluminized or bare steel (add \$50 for bare steel).

### 1967/1968 Shelby GT-500 & Mustang 390 GT H-Pipe - \$465/each

Part Number  
**EX-HP1**



Concours correct H-pipe for 1967/1968 Shelby GT-500 w/428 P.I. and 1967/1968 Mustangs w/390 GT & dual exhaust. Guaranteed to fit just like the originals. 100% accurate bends with all factory features. Available in aluminized or bare steel (add \$50 for bare steel).

### 1969/70 Shelby GT-350 & Mustang 351 Windsor H-Pipe - \$485/each

Part Number  
**EX-HP6**



Concours correct H-pipe for 1969 Mustangs w/351 Windsor engines & dual exhaust. Also correct for 1969/70 Shelby GT-350 Mustangs. Guaranteed to fit just like the originals. 100% accurate bends with all factory flats and tabs. Available in aluminized or bare steel (add \$50 for bare steel).

## Shelby, Boss, & Mustang Items for Sale Spring 2011

### 1967 Shelby GT-350 and 1967 289 HiPo H-Pipe - \$465/each

Part Number  
**EX-HP2**



100% accurate reproduction of the H-pipe used on 1967 Shelby GT-350s and 1967 Mustangs with 289 HiPo engines (K-Code) and dual exhaust. 100% accurate bends with all factory flats and tabs. Available in aluminized or bare steel (add \$50 for bare steel).

### 1970 428 CJ/SCJ H-Pipe - \$465/each

Part Number  
**EX-HP8**



**New Item** - Concours correct H-pipe for 1970 CJ/SCJ Mustangs **without** the spacer on the passenger-side exhaust manifold. Guaranteed to fit just like the originals. 100% accurate bends with all factory flats and stop tabs. Correct cross-over tube and flanges. Available in aluminized or bare steel (add \$50 for bare steel).

### 1969 Mustang/Shelby/Boss Resonator Pipes - \$1,145/pair

Part Number  
**EX-RP2**



100% accurate reproduction of the intermediate/resonator pipes used on:

- 1969 Mustangs with 428 CJ/SCJ (inc Mach I)
- 1969/1970 Shelby GT-500
- 1969 Boss 429/302

Available in aluminized or bare steel (add \$100 for bare steel).

### 1967/68 Shelby/Mustang 2-in Resonator Pipes - \$1,145/pair

Part Number  
**EX-RP3**



100% accurate reproduction of the intermediate/resonator pipes used on:

- 1967 Mustangs with 289 GT & 390 GT
- 1967 Shelby GT-500 & GT-350
- 1968 Mustangs with 302 GT & 390 GT
- 1968 Shelby GT-500 & GT-350

Available in aluminized or bare steel (add \$100 for bare steel).

## Shelby, Boss, & Mustang Items for Sale Spring 2011

### 1969/70 Shelby GT-350 & Mustang 351W Resonator Pipes- \$1,275/pair

Part Number  
**EX-RP4**



100% accurate reproduction of the intermediate/resonator pipes used on:

- 1969/1970 Shelby GT-350 Mustang
- 1969 Mustang w/351 Windsor & dual exhaust

Patterned after original assembly line parts. Available in aluminized or bare steel (add \$100 for bare steel).

### 1968½ GT500KR & 1968½ CJ Mustang Resonator Pipes - \$1,250/pair

Part Number  
**EX-RP1**



100% accurate reproduction of the intermediate/resonator pipes used on:

- 1968½ Shelby GT500KR Mustangs
- 1968½ Mustangs w/428 Cobra Jet Engine

Patterned after original assembly line parts. Available in aluminized or bare steel (add \$100 for bare steel).

### 1966 Shelby GT-350 and 1965/66 Mustang Dual Exhaust - Call for Price

Part Number  
**EX-661**



**New Item** - Concours correct reproduction of the exhaust used on 1966 Shelby, 1965/66 Mustang GT (A-code), and 1965/66 Mustang K-codes. Correct dated FoMoCo mufflers and correct style resonators. Muffler dates TBD.

**Expected Completion Date - Spring 2011**

### 1970 Boss 429, Boss 302, & CJ/SCJ Mustang Exhaust - Call for Price

Part Number  
**EX-701**



**New Item** - Concours correct reproduction of the exhaust used on 1970 Boss 429, Boss 302, and CJ/SCJ Mustang (non-GT). Correct dated Ford mufflers with large or small oval "Ford" depending on muffler production date. Muffler dates TBD.

**Expected Completion Date - Summer 2011**

## Shelby, Boss, & Mustang Items for Sale Spring 2011

### 1969/1970 Shelby GT-350 Tailpipes & Adapters - \$195/pair

Part Number  
**EX-TP4**



Concours correct reproduction of the tailpipes and adapters used on all 1969/1970 Shelby GT-350s. These are the 2-piece pipes that go between the transverse muffler and exhaust collector. Patterned after original pieces and press bent...just like the originals.

### 1969/1970 Shelby GT-350 Adapters - \$50/pair

Part Number  
**EX-TP4A**

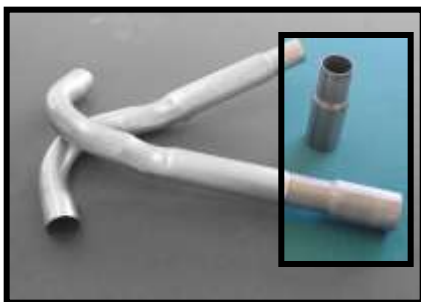

Concours correct reproduction of the adapters used on all 1969/1970 Shelby GT-350s. These are the adapters that clamp onto the tailpipe and go inside the exhaust collector. Patterned after original pieces removed from an original Shelby GT-350.

### 1968½ Shelby GT500KR & 428 Cobra Jet Mustang Tailpipes - \$545/pair

Part Number  
**EX-TP5**



100% perfect reproduction of tailpipes used on 1968½ Shelby GT500KR and 1968½ 428 Cobra Jet powered Mustangs. Correct welded tips and Ford logo and part number stamped into the pipe. Made from 2.25-in aluminized tubing...just like the originals.

### 1967/68/69 Shelby and Mustang GT Tailpipes - \$150/pair

Part Number  
**EX-TP6**



Concours correct reproduction of the tailpipes used on 1967 and 1968 Shelby GT350 & GT-500 (excludes KR), and 1967/68/69 Mustangs and Mach I with 2-inch dual exhaust (excludes CJ/SCJ). Patterned after original pieces and press bent...just like the originals.

## Shelby, Boss, & Mustang Items for Sale Spring 2011

### 1969 428 CJ/SCJ GT Mustang/Mach I Mustang Tailpipes - \$545/pair

Part Number  
**EX-TP1**



100% perfect reproduction of tailpipes used on 1969 Mustang GT with 428 Cobra Jet & Super Cobra Jet engines, and 1969 Mustang Mach I with 428 Cobra Jet & Super Cobra Jet engines. Correct welded tips and Ford logo and part number stamped into the pipe. Made from 2.25-in aluminized tubing...just like the originals.

### 1969 Boss 429/302 & 428 CJ/SCJ Non-GT Mustang Tailpipes - \$395/pair

Part Number  
**EX-TP2**



100% perfect reproduction of tailpipes used on 1969 Boss 429, Boss 302, and non-GT Mustangs with 428 Cobra Jet & Super Cobra Jet engines. Correct Ford logo and part number stamped into the pipe. Made from 2.25-in aluminized tubing...just like the originals.

### 1969/1970 Shelby GT-500 Tailpipes - \$365/pair

Part Number  
**EX-TP3**



Concours correct reproduction of tailpipes used on 1969/1970 Shelby GT-500s. Ford logo and part number stamped into the pipe...just like the originals. Made from 2.25-in aluminized tubing. This is the pipe that goes between the transverse muffler and the exhaust collector.

### 1965 - 1966 Shelby Tailpipe Tip - Call for Price

Part Number  
**EX-TIP4**



**New Item** - Concours perfect copy of the correct turn-down style tips used on all 1966 Shelybs and 1965/66 Mustang K-codes (non-GT). Exactly like the originals with C5ZA-5C262-A part number stamped into the tip, just like the originals. Concours correct tailpipe clamp (part #EX-MC6) also available.

## Shelby, Boss, & Mustang Items for Sale Spring 2011

### 1968½ Shelby GT500KR & CJ Mustang Transverse Muffler - \$675/each

Part Number  
EX-MU1



Exact duplicate of the transverse muffler used on all 1968½ Mustangs (including GT500KR Shelby Mustangs & all Mustangs with 428 Cobra Jet engines). Correct and accurate in every detail. All features of the new muffler were taken from original Ford 1968½ mufflers and vintage Ford engineering drawings...no guesswork here.

### 1969 Mustang/Shelby/Boss Transverse Muffler - \$675/each

Part Number  
EX-MU2



100% perfect reproduction of the transverse muffler used on 1969 Mustangs and Shelbys with 428 Cobra Jet/Super Cobra Jet and all 1969 Boss 429s and Boss 302s. Correct and accurate in every detail. Welded inlet and outlet pipe adapters and alignment notches...just like the originals. Four date codes to choose from - 8/68, 11/68, 1/69, and 3/69.

### 1967 Shelby GT-500/350 & Mustang GT Transverse Muffler - \$675/each

Part Number  
EX-MU3

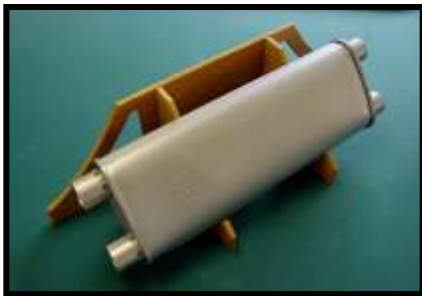

**New Item** - Reproduction of the transverse muffler used on 1967 Shelbys and Mustangs with 2-inch dual exhaust. Correct and accurate in every detail. Spot welded inlet and outlet pipes and alignment notches...just like the originals. Choose from 8/66, 12/66, and 1/67 muffler dates.

### 1968 Shelby GT-500/350 & Mustang GT Transverse Muffler - \$675/each

Part Number  
EX-MU4



**New Item** - Reproduction of the transverse muffler used on 1968 Shelbys and Mustangs with 2-inch dual exhaust. Correct and accurate in every detail. Spot welded inlet and outlet pipes and alignment notches...just like the originals. Choose from 8/67, 12/67, 3/68, and 5/68 dates.

## Shelby, Boss, & Mustang Items for Sale Spring 2011

### 1969 GT-350 & Mach I/Mustang GT Transverse Muffler - \$TBD/each

Part Number  
EX-MU5



Reproduction of the transverse muffler used on 1969 Shelby GT-350s and Mach Is/Mustangs with 2-inch dual exhaust. Correct and accurate in every detail. Spot welded inlet and outlet pipes and alignment notches...just like the originals. Date codes TBD.

Expected Completion Date - 2011

### 1967 Shelby GT-500/GT-350 Tailpipe Tips (Late Variant) - \$325/Pair

Part Number  
EX-TIP1



**New Item** - Conco's perfect reproduction of the one-piece exhaust tips used on 1967 Shelby GT-500s and GT-350s. This one-piece formed tip was used on Shelbys with car numbers starting after about 1600, however the exact cutoff date for the early variant (below) and the one-piece variant (shown here) is not known.

### 1967 Shelby GT-500/GT-350 Tailpipe Tips (Early Variant) - \$325/Pair

Part Number  
EX-TIP2



**New Item** - Conco's perfect reproduction of the two-piece welded exhaust tips used on 1967 Shelby GT-500s and GT-350s. This two-piece welded tip was used on Shelbys with car numbers starting before about 1600, however the exact cutoff date for the early variant (shown here) and the one-piece variant (above) is not known.

### 1968 Shelby GT-500 & GT-350 Tailpipe Tips - \$375/Pair

Part Number  
EX-TIP3



**New Item** - Conco's perfect reproduction of the pipe-within-a-pipe exhaust tips used on 1968 Shelby GT-500s and GT-350s. Correct spot welded construction with painted black-out...just like the originals.

## Shelby, Boss, & Mustang Items for Sale Spring 2011

### 1967/1968 Mustang and Shelby Convertible Floor Pan Plugs - \$135/pair

Part Number  
MS-FPP



Exact duplicate of the original steel floor pan plugs used on all 1967 and 1968 Mustang convertibles (including 1968 Shelby GT-350, GT-500, and GT500KR). The new plugs are correct in every detail, right down to the stamping of the part number, diameter, and manufacturer logo in the center.

### 1967 - 1970 Shelby/Boss/Mustang Front Sway Bar Brackets - \$75/pair

Part Number  
SU-SBB1



Concours exact reproduction of the front sway bar brackets used on all Mustangs between 1967 - 1970 with Competition Suspension Option or 15/16-inch sway bar. Never available until now. Stamped (not laser cut) like the originals and formed to exactly match assembly line parts. Like the originals in every detail.

### 1969 - 1970 Boss 429 Front Sway Bar Brackets - \$85/pair

Part Number  
SU-SBB2



Concours exact reproduction of the front sway bar brackets used on 1969 & 1970 Boss 429 with Competition Suspension Option and 15/16-inch sway bar. Never available until now. Stamped (not laser cut) like the originals and formed to exactly match assembly line parts. Like the originals in every detail.

### 1968½ GT500KR & CJ Mustang Sway Bar Brackets/Spacers - \$100/pair

Part Number  
SU-SBB3



Concours exact reproduction of the front Sway bar brackets and spacers used on 1968½ Shelby GT500R and Mustang w/428 CJ engine. Never available until now. Exactly like the originals.

Front sway bar bracket spacers available separately for \$25/pair

Part Number SU-SBB3A

## Shelby, Boss, & Mustang Items for Sale Spring 2011

### 1968 Mustang Spare Wheel Plate for Styled Steel Wheels – \$23/each

Part Number  
TR-HDP



100% perfect reproduction of the spare wheel hold down plate used on 1968 Mustangs with styled steel wheels. Reproduced from documented original parts and confirmed using original Ford factory engineering drawings. A part rarely seen and never reproduced until now.

### 1967-1970 Muffler and H-Pipe Exhaust Clamps - \$14/each

Part Number  
2-inch EX-MC1  
2 1/8-inch EX-MC2  
2 1/4-inch EX-MC3



Concours correct exhaust clamps for 1967-1970 Shelybys, Mustangs, Boss 429s, and Boss 302s. Reproduced from documented original clamps and confirmed using original Ford engineering drawings. FoMoCo and Ford logos where appropriate. Six clamps required per car. Call for the correct clamps for your application.

### 1968½-1973 Mustang/Shelby/Boss 2.25-inch Tailpipe Clamps - \$19/each

Part Number  
EX-MC4



Perfect reproduction of the tailpipe clamps used on all Mustang, Shelby, and Boss 429/302s with 2.25-inch exhaust. Dual-width band clamp with correct dark phosphate screw. "9A" and "P" stamped into the clamp...exactly like the originals. Nothing laser cut...stamped steel just like Ford did it. Two clamps required per car.

### 1967-1969 Mustang and Shelby 2-inch Tailpipe Clamps - \$19/each

Part Number  
EX-MC5



**New Item** - Perfect reproduction of the tailpipe clamps used on all Mustangs and Shelybys with 2-inch exhaust. Dual-width band clamp with correct dark phosphate screw. "8-A" and "FoMoCo" stamped into the clamp...exactly like the originals. Nothing laser cut...stamped steel just like Ford did it. Two clamps required per car.

## Shelby, Boss, & Mustang Items for Sale Spring 2011

### 1965-1969 Mustang, Mach I, & Shelby Tailpipe-to-Tip Clamps - \$14/each

Part Number  
EX-MC6



Perfect reproduction of the horseshoe clamps used to clamp the exhaust tip (Part # EX-TIP1/2/3) to the tailpipe (Part # EX-TP6) for cars with 2-inch exhaust. Used on Mustang GT, Mach I, and Shelbys. Two clamps required per car.

### 1967 - 1969 Exhaust Tailpipe "J" Hook - \$25/each

Part Number  
EX-RH1



**New Item** - Concoors exact reproduction of the J-hook used on all dual exhaust Shelbys and Mustangs. Stamped "FoMoCo" with a "G" just like the originals. This part is one of several pieces used to connect the tailpipe to the rear frame. Two parts are required per car (one for each tailpipe)

### 1969 Boss 429 Lug Nuts - \$385/car Set

Part Number  
MS-LN1



**New Item** - Concoors exact reproduction of the stainless capped lug nut used on 1969 Boss 429s. Deep drawn stainless steel formed cap with encapsulated hex nut. Made entirely from scratch to exactly match the original lug nuts installed on the assembly line by Kar Kraft. **Very limited supply.**

### 1965 - 1969 Exhaust Hanger Insulator - \$25/each

Part Number  
EX-RH3



**New Item** - Concoors exact reproduction of the rubber insulator used on all dual exhaust Shelbys and Mustangs. Stamped "FoMoCo" just like the originals. This part is one of several pieces used to connect the tailpipe to the rear frame. Two parts are required per car (one for each exhaust side).

**Expected Completion Date - Spring 2011**

## Shelby, Boss, & Mustang Items for Sale Spring 2011

### 1968 Shelby/Mustang & 1969 Boss 429 Spare Tire J-Bolt - \$14.95/each

Part Number  
TR-JB1

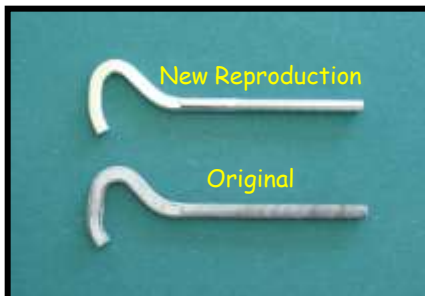

Concours correct copy of the spare tire J-bolt used on all 68 Shelybys/Mustangs & 1969 Boss 429s. Exactly like the originals...rolled threads, flattened end, & plated according to Ford engineering drawings.

- Overall Length -> 9.00-inches
- Thread Length -> 4-inches
- Thread Type -> 1/2-13 coarse thread

### 1969 Mustang, 69/70 Boss 302, & 70 Boss 429 Spare Tire J-Bolt - \$16.95

Part Number  
TR-JB2

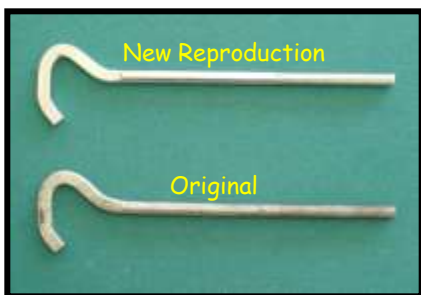

Concours correct copy of the spare tire J-bolt used on 1969/70 Mustangs. Exactly like the originals...rolled threads, flattened end, and plated according to the Ford engineering drawing.

- Overall Length -> 12.00-inches
- Thread Length -> 4-inches
- Thread Type -> 1/2-13 coarse thread

### 1969/1970 Shelby Spare Tire J-Bolt - \$14.50/each

Part Number  
TR-JB3

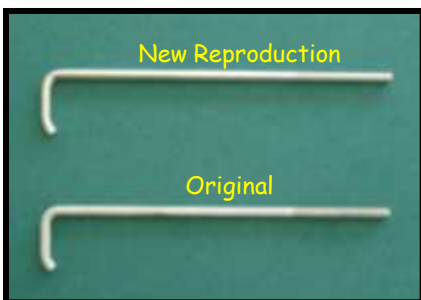

Concours correct copy of the spare tire J-bolt used on all 1969/70 Shelybys. Exactly like the originals...rolled threads, L-hook end, and plated according to the Ford engineering drawing.

- Overall Length -> 11.00-inches
- Thread Length -> 3-inches
- Thread Type -> 3/8-16 coarse thread

### 1969 Mustang Spare Tire J-Bolt - \$12.95/each

Part Number  
TR-JB4



Concours correct copy of the spare tire J-bolt used on 69 Mustangs w/steel wheels. Exactly like the originals...rolled threads, flattened end, and plated according to the Ford engineering drawing.

- Overall Length -> 6.50-inches
- Thread Length -> 3-inches
- Thread Type -> 1/2-13 coarse thread

## Shelby, Boss, & Mustang Items for Sale Spring 2011

### Shelby, Boss, & Mustang Spare Tire J-Bolt Wing Nut – \$5/each

Part Number  
1/2-13 TR-WN1  
3/8-16 TR-WN2

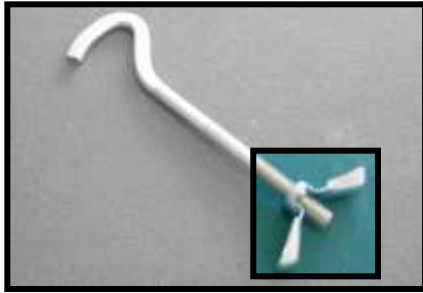

Reproduction of the spare tire J-bolt wing nut used to secure the spare tire, jack, and jack handle.

Available in 1/2-13 course thread & 3/8-16 course thread.

- 1/2 - 13 thread correct for TR-JB1/2/4
- 3/8 - 16 thread correct for TR-JB3

### 1968 Shelby & Mustang Front Parking/Marker Light Clip – \$25/each

Part Number  
MS-CLP1



Concours exact reproduction of the clip that holds the wires for the front marker light and parking light on all 1968 Shelybs and Mustangs. These clips are always broken or missing. Never available until now. Injection molded just like the originals. Each car gets two.

### 1968/69 Mustang & Boss Front Marker Light Wiring Clip – \$20/each

Part Number  
MS-CLP2



Concours exact reproduction of the front parking light wiring clip used on all 1968 Shelybs and Mustangs, and 1969 Mustangs, Boss 302s, and Boss 429s. Never before available. Injection molded just like the originals. Each car gets two.

### 1968/1969 Shelby and Mustang Tilt-A-Way Column Pin - \$25/each

Part Number  
MS-PIN1



Concours Perfect reproduction of the injection molded pin used in 1968/1969 Mustangs and Shelybs with the Tilt-A-Way column option. Absolutely indistinguishable from the original. Injection molded...just like the originals. Amber color...just like the originals. **Very limited supply.**

## Shelby, Boss, & Mustang Items for Sale Spring 2011

### Fiber Exhaust Manifold-to-H-Pipe Donut Gasket - \$6/each

Part Number  
**EX-GAS2**



Two-inch inside diameter fiber gasket used to seal the exhaust gases between the exhaust manifolds and H-pipe.

Correct for:

- 1967 289, 390, 428
- 1968 302, 390, 428 (except CJ)

### Cast Steel Exhaust Manifold-to-H-Pipe Donut Gasket - \$12/each

Part Number  
**EX-GAS1**



2-1/8 inch inside diameter cast steel gasket used to seal the exhaust gases between the exhaust manifolds and H-pipe.

Correct for:

- 1968 $\frac{1}{2}$  428 CJ
- 1969 428 CJ/SCJ, Boss 429
- 1970 428 CJ/SCJ, Boss 429

### 1967 - 1969 Mustang/Shelby Tie Rod End Boots- \$20/each

Part Number  
**SU-TEB1**



Concours correct reproduction of the tie rod end dust/grease boots used on 1967-1969 Mustangs and Shelys. Reproduced from documented original parts and confirmed using original Ford engineering drawings. Four boots required for one car.

### 1969 Boss 429/Boss 302/Shelby Tie Rod End Boots- \$25/each

Part Number  
**SU-TEB2**



Concours correct reproduction of the tie rod end dust/grease boots used on 1969 Boss 429/302 Mustangs and Shelys with "big-suspension". Reproduced from documented original parts and confirmed using original Ford engineering drawings. Four boots required for one car.

## Shelby, Boss, & Mustang Items for Sale Spring 2011

### 1965-1970 Exhaust Bracket-to-Hanger Bolts - \$3/each

Part Number  
**EX-RB1**



Correct indented hex head bolt used to attach the resonator brackets & muffler brackets to the hanging bracket (attaches to the bottom of the car). Four required per car.

### 1968 Shelby Dynamite Stick Installation Kit - \$25/each package

Part Number  
**EL-DS2**



Everything you need to "correctly" install dynamite sticks, just like the factory installed them. You get 6-bone colored Scotch-Lok wiring connectors and 2-unique wire ties for securing the dynamite sticks to the taillight panel. Complete and detailed instructions are included.

### Starter Delay Parts Package - \$50/each package

Part Number  
**EL-SR2**



You get three items:

- 3-Concours Correct self-tapping screws (two for the cap and one for the ground wire under the cap) with "C" lettered screw head
- One sponge-rubber starter delay lid gasket
- One starter delay lead wire with grommet and connector

### 1968 Shelby Console Weather Stripping - \$35/each

Part Number  
**MS-WS1**



**New Item** - Concours perfect reproduction of the console weather stripping used on all 1968 Shelbys (GT-350, GT-500, and GT500KR). Copied from original pieces. Never before reproduced until now. Exact copy in every detail. One piece required per car/console.

# Shelby, Boss, & Mustang Items for Sale Spring 2011

1968 Front Wiring Harness Shields (A/C Cars) - \$50/pair

Part Number  
MS-CLP3



**New Item** - Concours exact reproduction of the unique plastic shield that attaches behind the two lower A/C condenser mounting screws. This plastic part is frequently missing, damaged, faded from heat, brittle, or broken. The new shields are exactly like the originals and ready to install. Two shields are required per car. **Very limited supply.**

## Scott Fuller Reproduction T-Shirts



Part Number  
MS-TSM  
MS-TSL  
MS-TSXL  
MS-TS2XL

Hey, everyone needs a cheap t-shirt. Beautiful silk-screened graphics on Hanes BEEFY-T cotton shirt.

Available in Gray or White

Sizes M, L, XL, and 2XL

\$10/each + shipping

Note: Shirts run about 1-size small



# *Reference Information*

Helpful Reference Information  
to Assist You with Product  
Selection, Application, and  
Installation



# Spare Wheel Mounting Bolt Application Information

	Standard Steel			Styled Steel (GT)			Space Saver		
	Wheel Mount Position	Jack Mount Location	J-Bolt Type	Wheel Mount Position	Jack Mount Location	J-Bolt Type	Wheel Mount Position	Jack Mount Location	J-Bolt Type
1968 Mustang	Face-Up	Under	EX-JB1	Face-Up	Under	EX-JB1	N/A	N/A	N/A
1968 Shelby	Face-Up	Under	EX-JB1	N/A	N/A	N/A	N/A	N/A	N/A
1969 Mustang-A	F-Down	Under	EX-JB4	Face-Up	On Top	EX-JB2	N/A	N/A	N/A
1969 Mustang-B	N/A	N/A	N/A	F-Down	Under	EX-JB4	N/A	N/A	N/A
1969 Shelby	N/A	N/A	N/A	N/A	N/A	N/A	Face-Up	On Top	EX-JB3
1969 Boss 429	N/A	N/A	N/A	N/A	N/A	N/A	Face-Up	Under	EX-JB1
1969 Boss 302	N/A	N/A	N/A	N/A	N/A	N/A	Face-Up	On Top	EX-JB2
1970 Mustang	Face-Up	On Top	EX-JB2	N/A	N/A	N/A	N/A	N/A	N/A
1970 Shelby	N/A	N/A	N/A	N/A	N/A	N/A	Face-Up	On Top	EX-JB3
1970 Boss 429	N/A	N/A	N/A	N/A	N/A	N/A	Face-Up	On Top	EX-JB2
1970 Boss 302	N/A	N/A	N/A	N/A	N/A	N/A	Face-Up	On Top	EX-JB2

Notes:  
**Face-Up** - Rim positioned in trunk with wheel face up  
**F-Down** - Rim positioned in trunk with wheel face down  
**Under** - Jack stows under spare tire  
**On Top** - Jack sits on top of rim  
**N/A** - Not used for this application

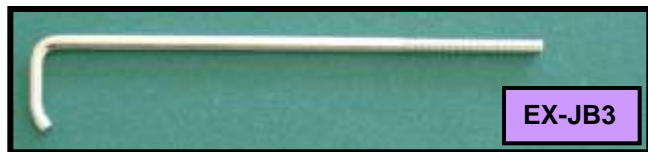

**Note:** In some instances there is more than one correct bolt per Mustang application. Where more than one bolt is shown for a particular application it is based on known bolts found in low-mileage/original cars and discussions with knowledgeable Mustang judges and restorers. Additionally, in some instances the matrix above will not match information in Ford assembly manuals, Ford parts catalogs, and other Ford documentation. Just because Ford assigned a part number to a part, doesn't necessarily indicate that they actually produced it or used it for the intended application. So, if there is no concrete evidence that the part was ever delivered in a car from the factory, it is not shown in the matrix above. For instance, the Ford parts manual shows a different bolt for standard wheel, GT wheel, and space saver in 1968. Considerable evidence exists that suggests that the GT wheel mounting bolt (according to the parts manual) was seldom if ever used during assembly and that Ford used the standard wheel mounting bolt instead. And even though the Ford parts manual shows a mounting bolt for space saver spares I am not aware of a space saver spare ever being factory-delivered in a Mustang in 1968.

# How to Decode a 1970 Assembly Line Muffler



Large Logo "Ford"  
Used before January 1970

Small Logo "Ford"  
Begins January 1970

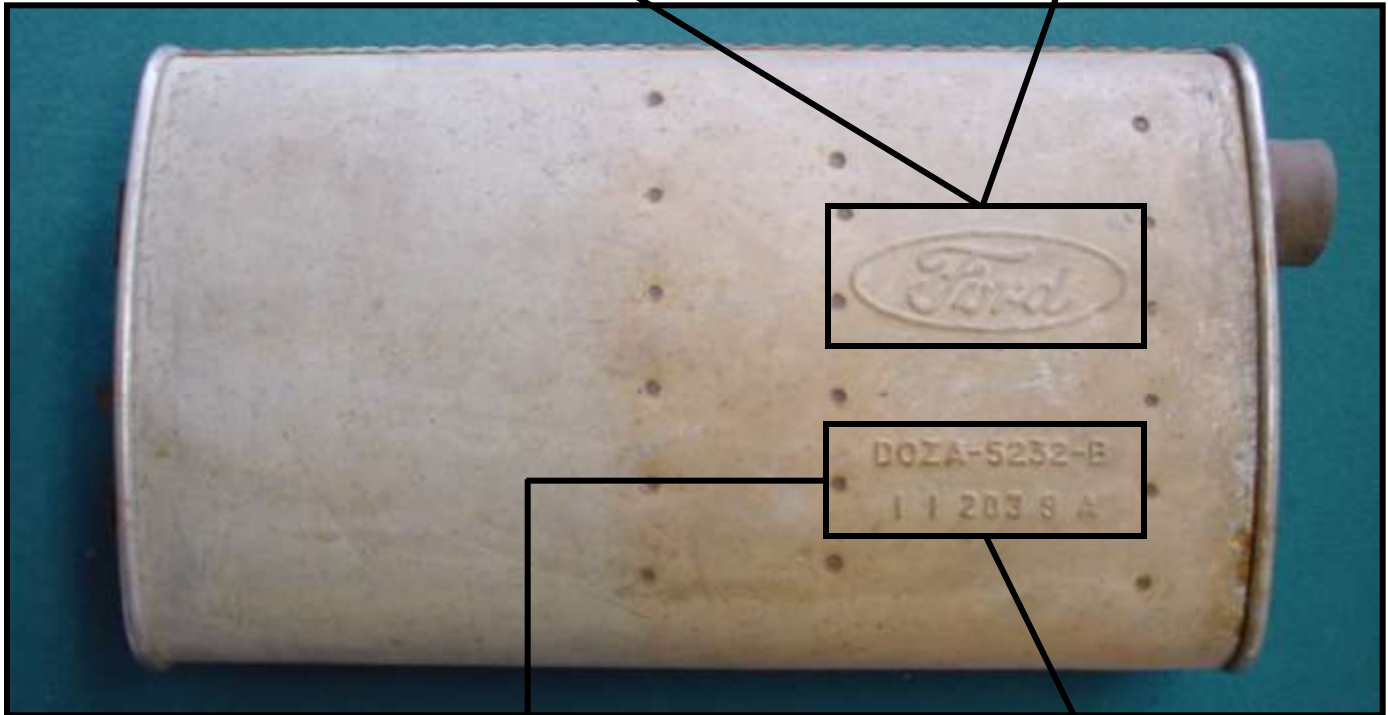

DOZA-5232-B

Boss 429/302  
Driver Side

DOZA-5230-D

Boss 429/302  
Pass Side

DOZA-5232-C

CJ/SCJ Mach  
Driver Side

DOZA-5230-E

CJ/SCJ Mach  
Pass Side

1 1 203 9 A

1<sup>st</sup> Hour  
of Shift  
1 - 8

203<sup>rd</sup>  
Day of  
Year  
1 - 365

Year  
1969  
1969 - 1970

Shift  
Number 1  
1 - 2

Arvin  
Muffler  
Manufacturer

# 1970 Boss 429, Boss 302, & CJ/SCJ Mach 1 Muffler Data

Driver Side Muffler DOZA-5232-B			
Muffler Fabrication Data			
Hour	Shift	Day	Date
1	1	203	22-Jul-69
4	1	267	24-Sep-69
2	2	203	22-Jul-69
7	1	029	29-Jan-70
1	2	029	29-Jan-70
6	1	300	27-Oct-69
5	1	318	14-Nov-69
5	2	238	26-Aug-69
1	2	029	29-Jan-70
1	1	203	22-Jul-69
Data unknown			
Data unknown			
Data unknown			
2	2	203	22-Jul-69
7	1	300	27-Oct-69
1	2	029	29-Jan-70
1	2	029	29-Jan-70
5	1	329	25-Nov-69
Data unknown			
4	1	328	24-Nov-69
4	2	238	26-Aug-69
8	1	300	27-Oct-69

Passenger Side Muffler DOZA-5230-D			
Muffler Fabrication Data			
Hour	Shift	Day	Date
1	2	238	26-Aug-69
6	1	300	27-Oct-69
Data unknown			
8	1	028	28-Jan-70
1	1	029	29-Jan-70
8	1	238	26-Aug-69
3	1	251	8-Sep-69
6	1	202	21-Jul-69
1	1	029	29-Jan-70
Data unknown			
8	1	237	25-Aug-69
1	2	237	25-Aug-69
1	1	029	29-Jan-70
1	2	202	21-Jul-69
8	1	238	26-Aug-69
1	1	029	29-Jan-70
1	1	029	29-Jan-70
Data unknown			
8	1	028	28-Jan-70
3	1	328	24-Nov-69
1	1	202	21-Jul-69
8	1	238	26-Aug-69

Notes:		
Matched Pair	Car	Car Build Date
Yes	Unknown	Unknown
Yes	Unknown	Unknown
No	Boss 302	2-Oct-69
Yes	Boss 302	29-Jun-70
Yes	Boss 302	Apr-70
Yes	Unknown	Unknown
Yes	Boss 429	22-Dec-69
Yes	Boss 302	Unknown
Yes	Boss 302	May-70
No	Unknown	Unknown
No	Unknown	Unknown
No	Unknown	Unknown
No	Boss 302	28-Apr-70
Yes	Boss 429	30-Sep-69
Yes	Unknown	Unknown
Yes	Boss 302	8-Jun-70
Yes	Boss 302	1-Jun-70
No	Boss 302	Unknown
No	Unknown	Unknown
Yes	Unknown	Unknown
Yes	Unknown	Unknown
Yes	Boss 429	Nov-69

Driver Side Muffler DOZA-5232-C			
Muffler Fabrication Data			
Hour	Shift	Day	Date
2	1	247	4-Sep-69
4	1	247	4-Sep-69

Passenger Side Muffler DOZA-5230-E			
Muffler Fabrication Data			
Hour	Shift	Day	Date
2	2	247	4-Sep-69
2	1	248	5-Sep-69

Notes:		
Matched Pair	Car	Car Build Date
Yes	SCJ Mach	22-Sep-69
Yes	SCJ Mach	Nov-69

Denotes Unknown Car Type  
 Denotes 1970 Boss 429

Denotes 1970 Boss 302  
 Denotes 1970 CJ/SCJ Mach 1

**Notes:**

- Ford switched from a "large oval Ford" embossed logo on the mufflers to a "small oval Ford" embossed logo on the mufflers at the end of calendar year 1969
- It appears that no mufflers were manufactured after the end of January 1970, even for June 1970 produced cars
- Later built cars appear to have more consistent muffler manufacturer dates (driver vs passenger) than earlier built cars



### Calendar of Known Muffler Production Dates for 1970 DOZA-5232-B/C (driver side muffler)

July 1969																														
1	2	3	4	5	6	7	8	9	10	11	12	13	14	15	16	17	18	19	20	21	22	23	24	25	26	27	28	29	30	31
Tues	Wed	Thurs	Fri	Sat	Sun	Mon	Tues	Wed	Thurs	Fri	Sat	Sun	Mon	Tues	Wed	Thurs	Fri	Sat	Sun	Mon	Tues	Wed	Thurs	Fri	Sat	Sun	Mon	Tues	Wed	Thurs
182	183	184	185	186	187	188	189	190	191	192	193	194	195	196	197	198	199	200	201	202	203	204	205	206	207	208	209	210	211	212

August 1969																														
1	2	3	4	5	6	7	8	9	10	11	12	13	14	15	16	17	18	19	20	21	22	23	24	25	26	27	28	29	30	31
Fri	Sat	Sun	Mon	Tues	Wed	Thurs	Fri	Sat	Sun	Mon	Tues	Wed	Thurs	Fri	Sat	Sun	Mon	Tues	Wed	Thurs	Fri	Sat	Sun	Mon	Tues	Wed	Thurs	Fri	Sat	Sun
213	214	215	216	217	218	219	220	221	222	223	224	225	226	227	228	229	230	231	232	233	234	235	236	237	238	239	240	241	242	243

September 1969																													
1	2	3	4	5	6	7	8	9	10	11	12	13	14	15	16	17	18	19	20	21	22	23	24	25	26	27	28	29	30
Mon	Tues	Wed	Thur	Fri	Sat	Sun	Mon	Tues	Wed	Thurs	Fri	Sat	Sun	Mon	Tues	Wed	Thurs	Fri	Sat	Sun	Mon	Tues	Wed	Thurs	Fri	Sat	Sun	Mon	Tues
244	245	246	247	248	249	250	251	252	253	254	255	256	257	258	259	260	261	262	263	264	265	266	267	268	269	270	271	272	273

October 1969																														
1	2	3	4	5	6	7	8	9	10	11	12	13	14	15	16	17	18	19	20	21	22	23	24	25	26	27	28	29	30	31
Wed	Thurs	Fri	Sat	Sun	Mon	Tues	Wed	Thurs	Fri	Sat	Sun	Mon	Tues	Wed	Thurs	Fri	Sat	Sun	Mon	Tues	Wed	Thurs	Fri	Sat	Sun	Mon	Tues	Wed	Thurs	
274	275	276	277	278	279	280	281	282	283	284	285	286	287	288	289	290	291	292	293	294	295	296	297	298	299	300	301	302	303	304

November 1969																													
1	2	3	4	5	6	7	8	9	10	11	12	13	14	15	16	17	18	19	20	21	22	23	24	25	26	27	28	29	30
Sat	Sun	Mon	Tues	Wed	Thurs	Fri	Sat	Sun	Mon	Tues	Wed	Thurs	Fri	Sat	Sun	Mon	Tues	Wed	Thurs	Fri	Sat	Sun	Mon	Tues	Wed	Thurs	Fri	Sat	Sun
305	306	307	308	309	310	311	312	313	314	315	316	317	318	319	320	321	322	323	324	325	326	327	328	329	330	331	332	333	334

December 1969																														
1	2	3	4	5	6	7	8	9	10	11	12	13	14	15	16	17	18	19	20	21	22	23	24	25	26	27	28	29	30	31
Mon	Tues	Wed	Thurs	Fri	Sat	Sun	Mon	Tues	Wed	Thurs	Fri	Sat	Sun	Mon	Tues	Wed	Thurs	Fri	Sat	Sun	Mon	Tues	Wed	Thurs	Fri	Sat	Sun	Mon	Tues	Wed
335	336	337	338	339	340	341	342	343	344	345	346	347	348	349	350	351	352	353	354	355	356	357	358	359	360	361	362	363	364	365

January 1970																														
1	2	3	4	5	6	7	8	9	10	11	12	13	14	15	16	17	18	19	20	21	22	23	24	25	26	27	28	29	30	31
Thurs	Fri	Sat	Sun	Mon	Tues	Wed	Thurs	Fri	Sat	Sun	Mon	Tues	Wed	Thurs	Fri	Sat	Sun	Mon	Tues	Wed	Thurs	Fri	Sat	Sun	Mon	Tues	Wed	Thurs	Fri	Sat
1	2	3	4	5	6	7	8	9	10	11	12	13	14	15	16	17	18	19	20	21	22	23	24	25	26	27	28	29	30	31

Denotes a Known Muffler Production Date for Boss 429 and Boss 302  
 Denotes a Known Muffler Production Date for CJ/SCJ Mach 1

### Calendar of Known Muffler Production Dates for 1970 DOZA-5230-D/E (pass side muffler)

July 1969																														
1	2	3	4	5	6	7	8	9	10	11	12	13	14	15	16	17	18	19	20	21	22	23	24	25	26	27	28	29	30	31
Tues	Wed	Thurs	Fri	Sat	Sun	Mon	Tues	Wed	Thurs	Fri	Sat	Sun	Mon	Tues	Wed	Thurs	Fri	Sat	Sun	Mon	Tues	Wed	Thurs	Fri	Sat	Sun	Mon	Tues	Wed	Thurs
182	183	184	185	186	187	188	189	190	191	192	193	194	195	196	197	198	199	200	201	202	203	204	205	206	207	208	209	210	211	212

August 1969																														
1	2	3	4	5	6	7	8	9	10	11	12	13	14	15	16	17	18	19	20	21	22	23	24	25	26	27	28	29	30	31
Fri	Sat	Sun	Mon	Tues	Wed	Thurs	Fri	Sat	Sun	Mon	Tues	Wed	Thurs	Fri	Sat	Sun	Mon	Tues	Wed	Thurs	Fri	Sat	Sun	Mon	Tues	Wed	Thurs	Fri	Sat	Sun
213	214	215	216	217	218	219	220	221	222	223	224	225	226	227	228	229	230	231	232	233	234	235	236	237	238	239	240	241	242	243

September 1969																													
1	2	3	4	5	6	7	8	9	10	11	12	13	14	15	16	17	18	19	20	21	22	23	24	25	26	27	28	29	30
Mon	Tues	Wed	Thur	Fri	Sat	Sun	Mon	Tues	Wed	Thurs	Fri	Sat	Sun	Mon	Tues	Wed	Thurs	Fri	Sat	Sun	Mon	Tues	Wed	Thurs	Fri	Sat	Sun	Mon	Tues
244	245	246	247	248	249	250	251	252	253	254	255	256	257	258	259	260	261	262	263	264	265	266	267	268	269	270	271	272	273

October 1969																														
1	2	3	4	5	6	7	8	9	10	11	12	13	14	15	16	17	18	19	20	21	22	23	24	25	26	27	28	29	30	31
Wed	Thurs	Fri	Sat	Sun	Mon	Tues	Wed	Thurs	Fri	Sat	Sun	Mon	Tues	Wed	Thurs	Fri	Sat	Sun	Mon	Tues	Wed	Thurs	Fri	Sat	Sun	Mon	Tues	Wed	Thurs	
274	275	276	277	278	279	280	281	282	283	284	285	286	287	288	289	290	291	292	293	294	295	296	297	298	299	300	301	302	303	304

November 1969																													
1	2	3	4	5	6	7	8	9	10	11	12	13	14	15	16	17	18	19	20	21	22	23	24	25	26	27	28	29	30
Sat	Sun	Mon	Tues	Wed	Thurs	Fri	Sat	Sun	Mon	Tues	Wed	Thurs	Fri	Sat	Sun	Mon	Tues	Wed	Thurs	Fri	Sat	Sun	Mon	Tues	Wed	Thurs	Fri	Sat	Sun
305	306	307	308	309	310	311	312	313	314	315	316	317	318	319	320	321	322	323	324	325	326	327	328	329	330	331	332	333	334

December 1969																														
1	2	3	4	5	6	7	8	9	10	11	12	13	14	15	16	17	18	19	20	21	22	23	24	25	26	27	28	29	30	31
Mon	Tues	Wed	Thurs	Fri	Sat	Sun	Mon	Tues	Wed	Thurs	Fri	Sat	Sun	Mon	Tues	Wed	Thurs	Fri	Sat	Sun	Mon	Tues	Wed	Thurs	Fri	Sat	Sun	Mon	Tues	Wed
335	336	337	338	339	340	341	342	343	344	345	346	347	348	349	350	351	352	353	354	355	356	357	358	359	360	361	362	363	364	365

January 1970																														
1	2	3	4	5	6	7	8	9	10	11	12	13	14	15	16	17	18	19	20	21	22	23	24	25	26	27	28	29	30	31
Thurs	Fri	Sat	Sun	Mon	Tues	Wed	Thurs	Fri	Sat	Sun	Mon	Tues	Wed	Thurs	Fri	Sat	Sun	Mon	Tues	Wed	Thurs	Fri	Sat	Sun	Mon	Tues	Wed	Thurs	Fri	Sat
1	2	3	4	5	6	7	8	9	10	11	12	13	14	15	16	17	18	19	20	21	22	23	24	25	26	27	28	29	30	31

Denotes a Known Muffler Production Date for Boss 429 and Boss 302  
 Denotes a Known Muffler Production Date for CJ/SCJ Mach 1

### 1968 Shelby/Mustang Wiring Clip Location



1968 Mustang Clip Location



New Reproduction Clip

### 1968 Shelby/Mustang & 1969 Mustang/Boss 429/302 Wiring Clip Location



1968 Mustang Clip Location



New Reproduction Clip



1969 Mustang Clip Location

# 1968/1969 Shelby & Mustang Tilt-A-Way Column Pin Location

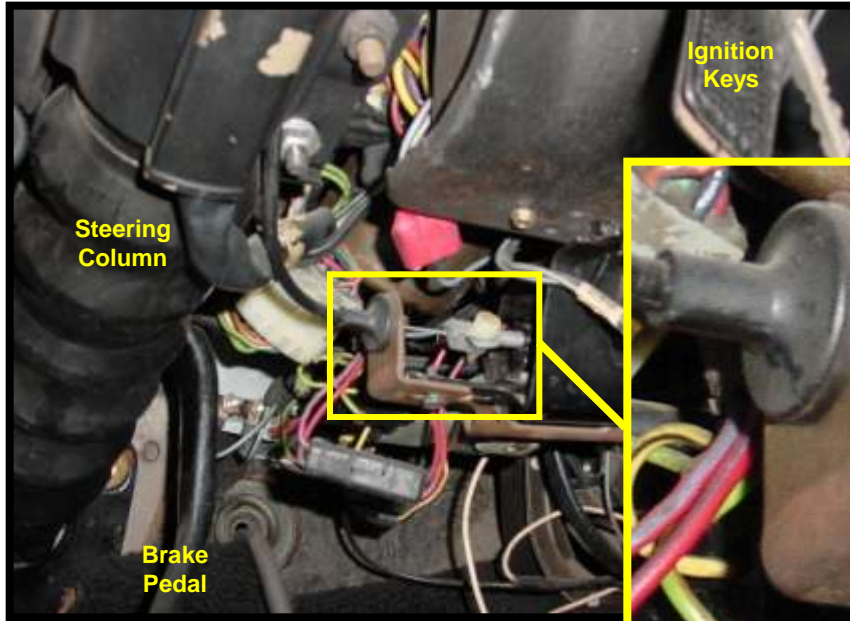

Above - Driver's side under-dash area

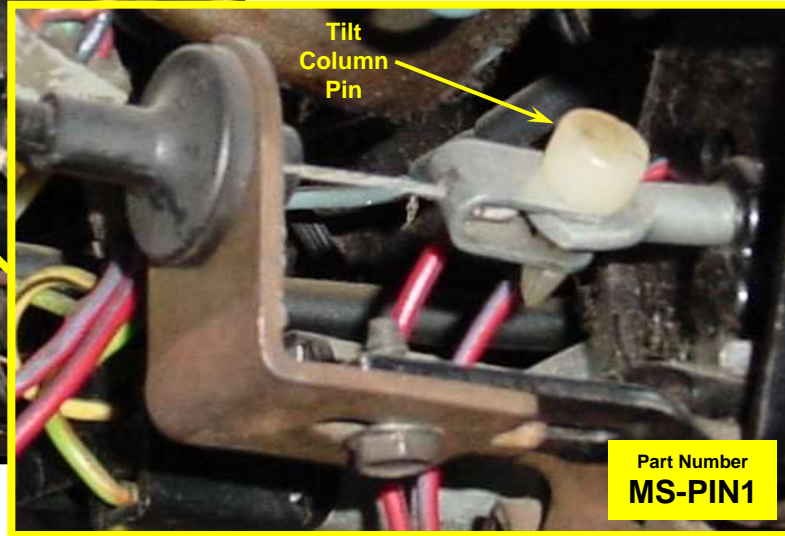

Above - Original tilt pin installed in 1968 Shelby Mustang

# 1968 Front Wiring Harness Shield (Air Conditioned Cars) Location

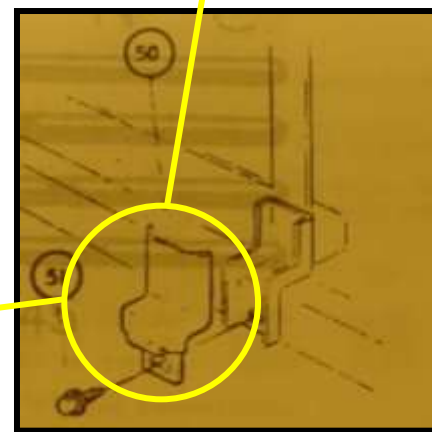
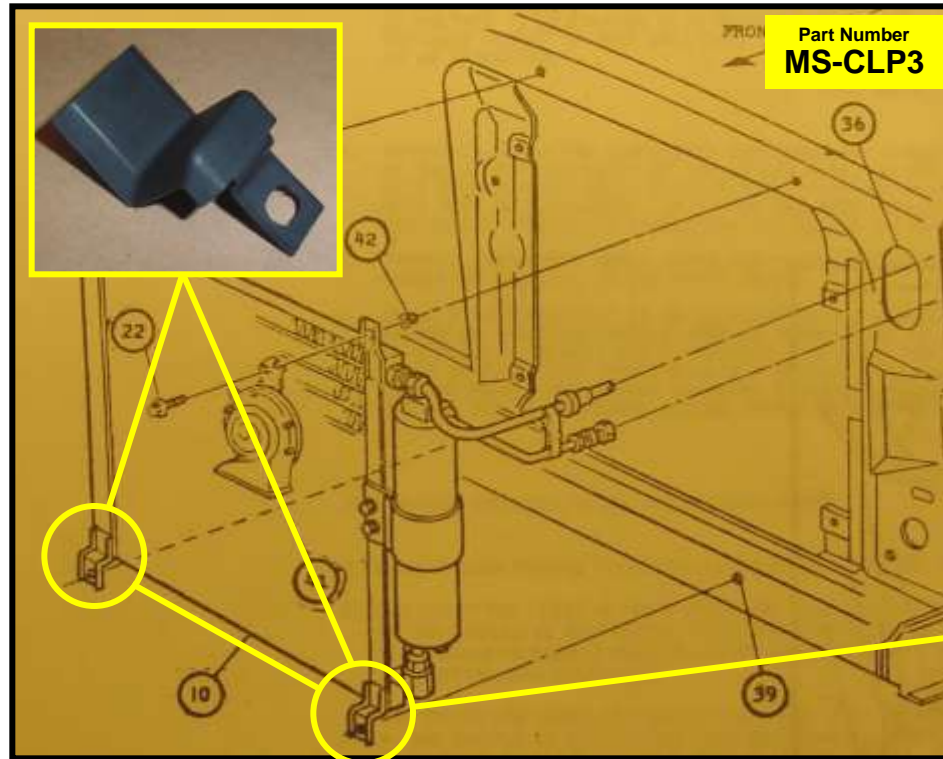



S.C.O.T.T F.U.L.L.E.R  
R.E.P.R.O.D.U.C.T.I.O.N.S

Concours Correct Exhaust  
For  
1965 – 1970 Shelby, Boss, and Mustang

Exhaust Supplement

1.7.6.3 F.e.l.s.p.a.r A.v.e R.i.d.g.e.c.r.e.s.t C.a.l.i.f.o.r.n.i.a 9.3.5.5.5

# 1965-1970 Shelby, Boss, and Mustang "Concours Correct" Exhaust

## 1965 Mustang Exhaust (after 3/65)

- 1965 Mustang GT w/289 (A&K-Code) (Pg S1)
- 1965 Mustang non-GT w/289 (K-Code) (Pg S1)

## 1966 Shelby and Mustang Exhaust

- 1966 Shelby GT-350 (Pg S2)
- 1966 Mustang GT w/289 (A&K-Code) (Pg S2)
- 1966 Mustang non-GT w/289 (K-Code) (Pg S3)

## 1967 Shelby and Mustang Exhaust

- 1967 Shelby GT-500 w/428 P.I. (Pg S3)
- 1967 Shelby GT-350 w/289 (Pg S4)
- 1967 Mustang GT w/390 and dual exhaust (Pg S4)
- 1967 Mustang GT w/289 and dual exhaust (Pg S5)

## 1968 Shelby and Mustang Exhaust

- 1968 Shelby GT500KR w/428 Cobra Jet (Pg S5)
- 1968 Shelby GT-500 w/428 P.I. (Pg S6)
- 1968 Shelby GT-350 w/302 (Pg S6)
- 1968 Mustang w/428 Cobra Jet and dual exhaust (Pg S7)
- 1968 Mustang GT w/390 & dual exhaust (Pg S7)
- 1968 Mustang GT w/302 & dual exhaust (Pg S8)

## 1969 Shelby, Boss, and Mustang Exhaust

- 1969/70 Shelby GT-500 w/428 CJ/SCJ (Pg S8)
- 1969/70 Shelby GT-350 w/351 Windsor (Pg S9)
- 1969 Boss 429 (Pg S9)
- 1969 Boss 302 (Pg S10)
- 1969 Mach I w/428 CJ/SCJ (Pg S10)
- 1969 Mach I w/351 Windsor (Pg S11)
- 1969 Mustang GT w/428 CJ/SCJ (Pg S11)
- 1969 Mustang non-GT w/428 CJ/SCJ (Pg S12)
- 1969 Mustang GT w/351 Windsor & dual exhaust (Pg S12)

## 1970 Shelby, Boss, and Mustang Exhaust

- 1970 Shelby GT-500 w/428 CJ/SCJ (see above)
- 1970 Shelby GT-350 w/351 Windsor (see above)
- 1970 Boss 429 (Pg S13)
- 1970 Boss 302 (Pg S13)
- 1970 Mustang w/428 CJ/SCJ (Pg S14)

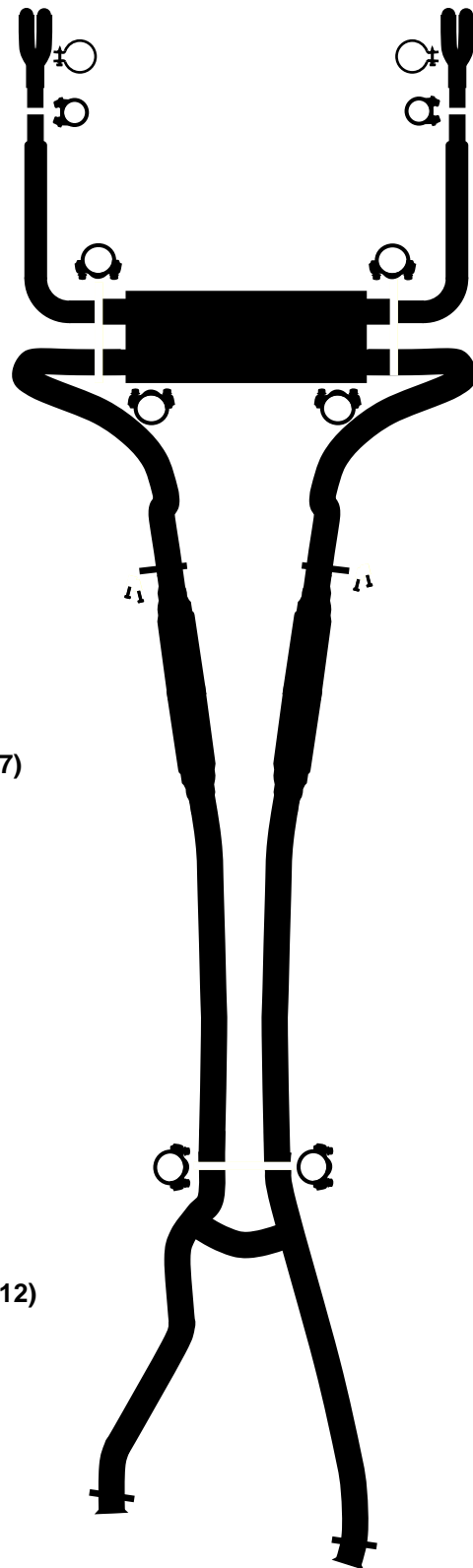

# 1965 Mustang GT w/289 (A-Code) & w/289 (K-Code) after 3/65

Part #	Page	Item	Aluminized	Bare Steel
		H-Pipe	Not Available	
EX-661	4	Main Pipes	Available Spring 2011	
		Tailpipe Tip	Not Available	
EX-MC1	10	Clamps (H-Pipe)	\$28	\$28
EX-MC6	11	Clamps (Horseshoe)	\$28	\$28
EX-GAS2	14	Ex Donut Gasket	\$12	\$12
EX-RB1	14	Muf Hanger Bolts	\$12	\$12
		<b>Total</b>	<b>TBD</b>	<b>TBD</b>

In production at time of catalog printing  
Items shown in gray in the diagram are currently not available but may be purchased from other sources, or may be produced by SFR at a later date

# 1965 Mustang non-GT w/289 (K-Code) after 3/65

Part #	Page	Item	Aluminized	Bare Steel
		H-Pipe	Not Available	
EX-661	4	Main Pipes	Available Spring 2011	
EX-TIP4	6	Tailpipe Tip	Available Spring 2011	
EX-MC1	10	Clamps (H-Pipe)	\$28	\$28
EX-MC6	11	Clamps (Horseshoe)	\$28	\$28
EX-GAS2	14	Ex Donut Gasket	\$12	\$12
EX-RB1	14	Muf Hanger Bolts	\$12	\$12
		<b>Total</b>	<b>TBD</b>	<b>TBD</b>

In production at time of catalog printing  
Items shown in gray in the diagram are currently not available but may be purchased from other sources, or may be produced by SFR at a later date

# 1966 Shelby GT-350 w/289 K-Code

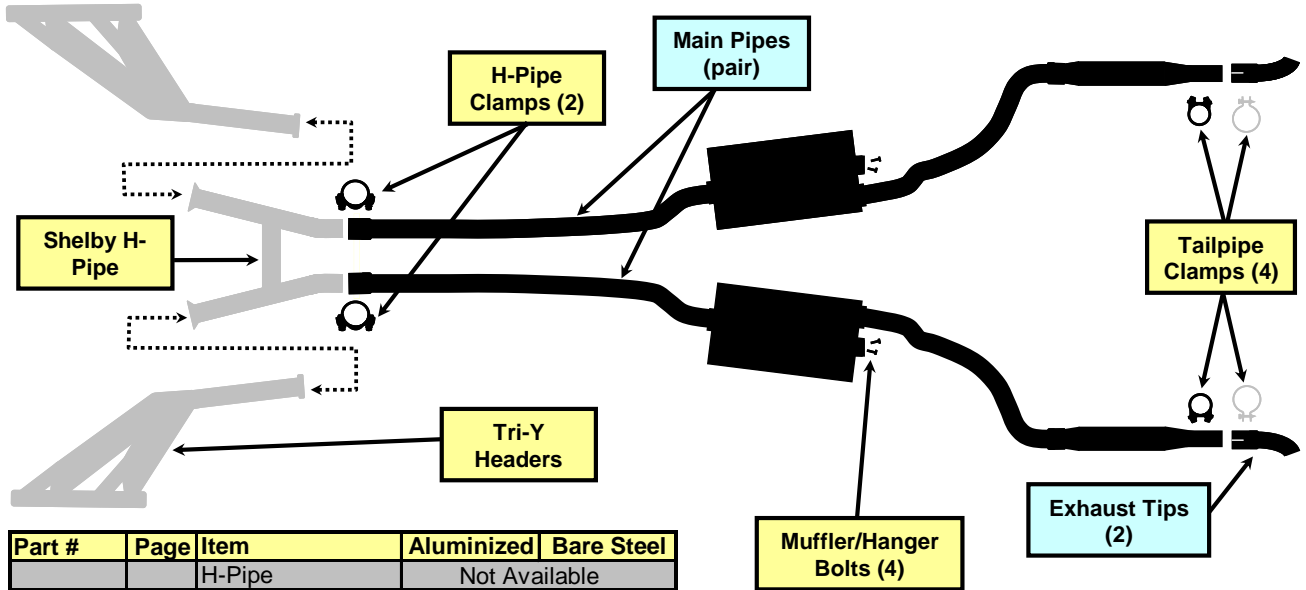

Part #	Page	Item	Aluminized	Bare Steel
		H-Pipe	Not Available	
EX-661	4	Main Pipes	Available Spring 2011	
EX-TIP4	6	Tailpipe Tip	Available Spring 2011	
EX-MC1	10	Clamps (H-Pipe)	\$28	\$28
EX-MC6	11	Clamps (Horseshoe)	\$28	\$28
EX-GAS2	14	Ex Donut Gasket	\$12	\$12
EX-RB1	14	Muf Hanger Bolts	\$12	\$12
		<b>Total</b>	<b>TBD</b>	<b>TBD</b>

  In production at time of catalog printing  
  Items shown in gray in the diagram are currently not available but may be purchased from other sources, or may be produced by SFR at a later date

# 1966 Mustang GT w/289 (A-Code) & w/289 (K-Code)

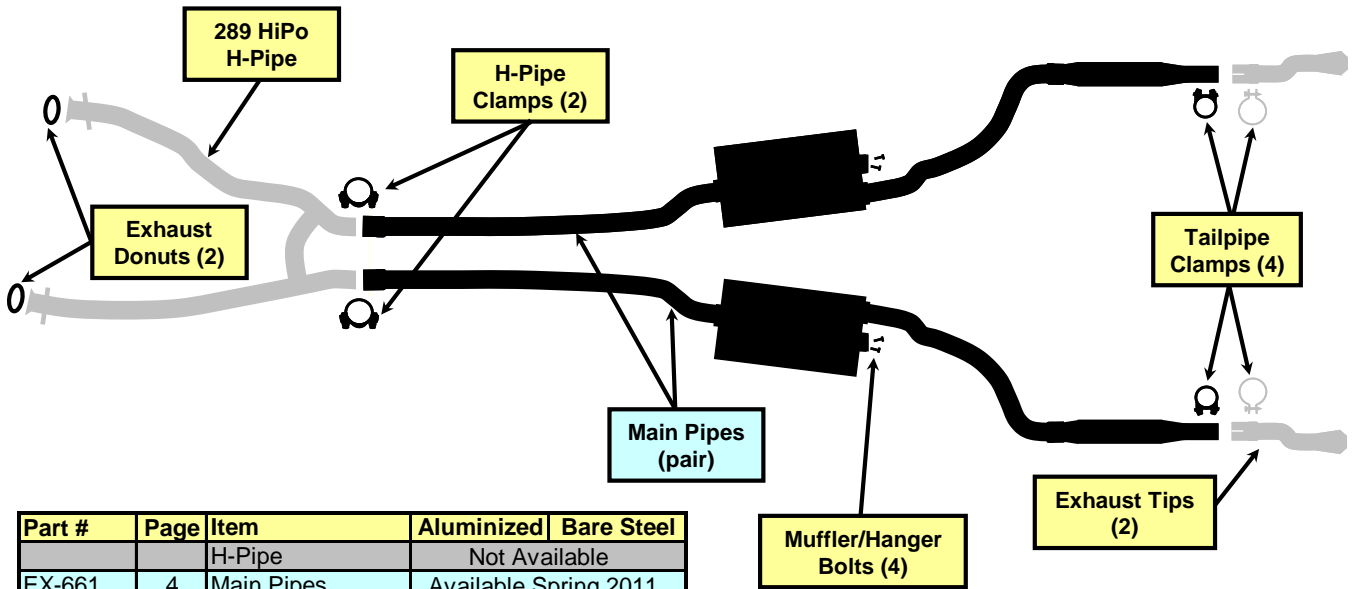

Part #	Page	Item	Aluminized	Bare Steel
		H-Pipe	Not Available	
EX-661	4	Main Pipes	Available Spring 2011	
		Tailpipe Tip	Not Available	
EX-MC1	10	Clamps (H-Pipe)	\$28	\$28
EX-MC6	11	Clamps (Horseshoe)	\$28	\$28
EX-GAS2	14	Ex Donut Gasket	\$12	\$12
EX-RB1	14	Muf Hanger Bolts	\$12	\$12
		<b>Total</b>	<b>TBD</b>	<b>TBD</b>

  In production at time of catalog printing  
  Items shown in gray in the diagram are currently not available but may be purchased from other sources, or may be produced by SFR at a later date

# 1966 Mustang non-GT w/289 (K-Code)

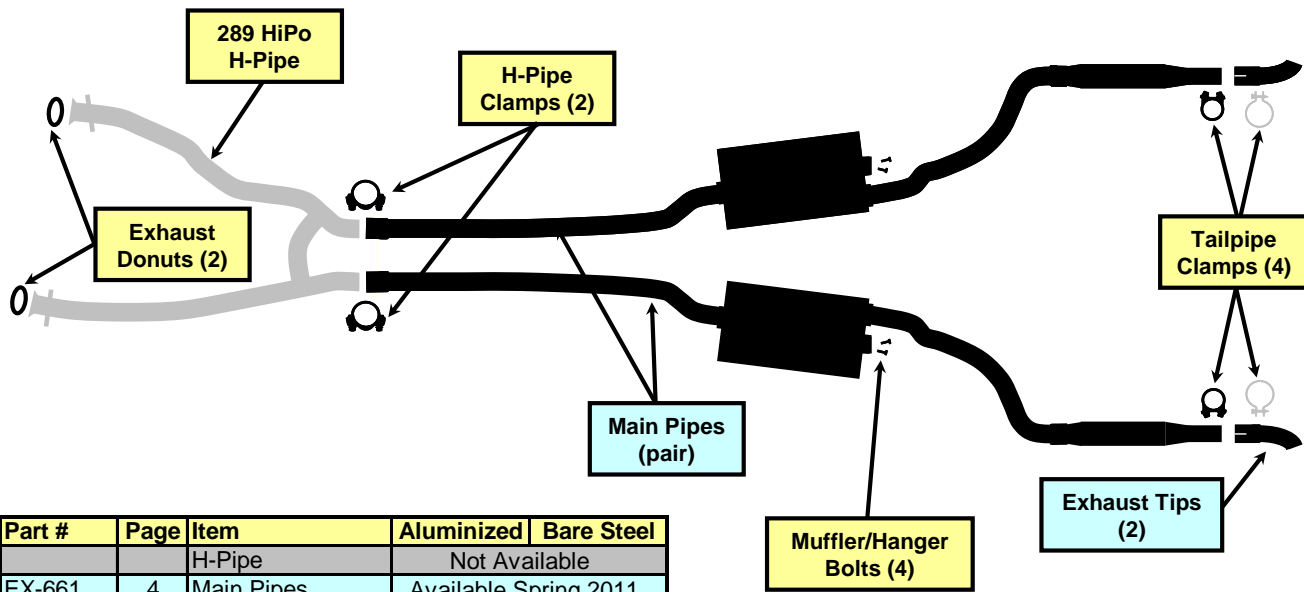

Part #	Page	Item	Aluminized	Bare Steel
		H-Pipe	Not Available	
EX-661	4	Main Pipes	Available Spring 2011	
EX-TIP4	6	Tailpipe Tip	Available Spring 2011	
EX-MC1	10	Clamps (H-Pipe)	\$28	\$28
EX-MC6	11	Clamps (Horseshoe)	\$28	\$28
EX-GAS2	14	Ex Donut Gasket	\$12	\$12
EX-RB1	14	Muf Hanger Bolts	\$12	\$12
		<b>Total</b>	<b>TBD</b>	<b>TBD</b>

In production at time of catalog printing  
Items shown in gray in the diagram are currently not available but may be purchased from other sources, or may be produced by SFR at a later date

# 1967 Shelby GT-500 w/428 P.I.

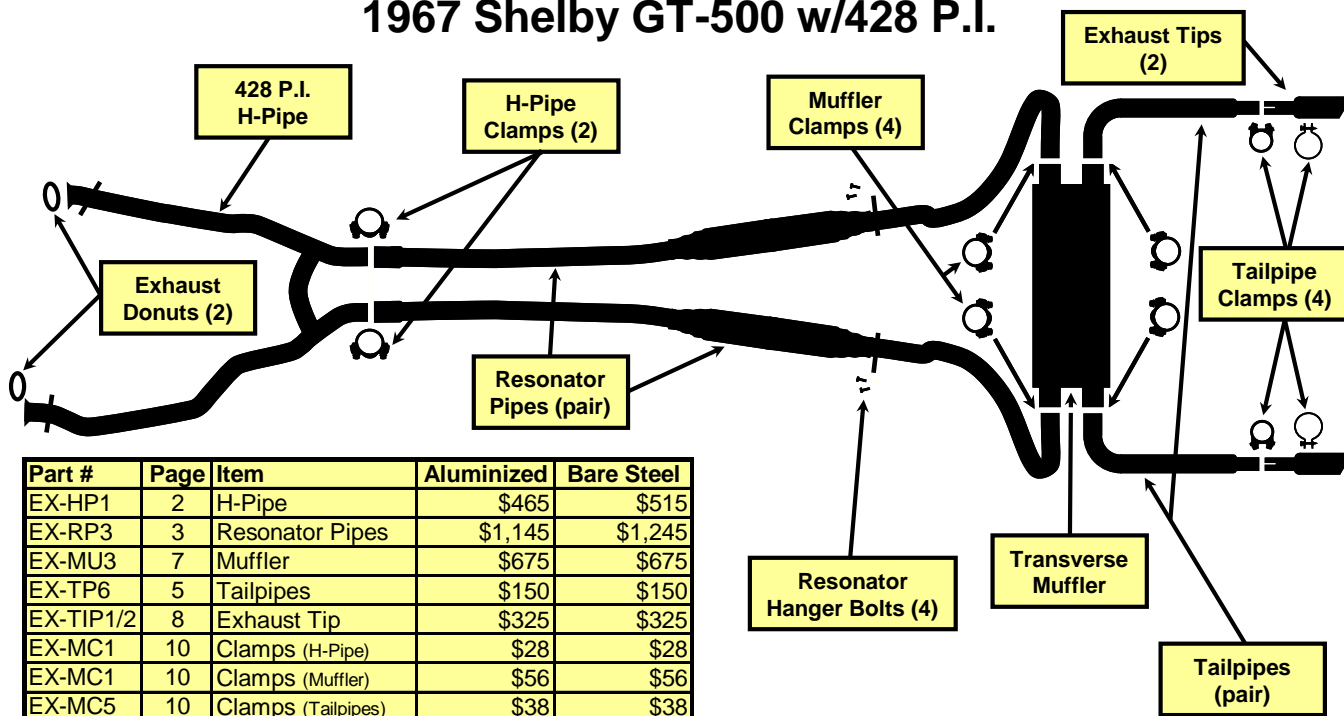

Part #	Page	Item	Aluminized	Bare Steel
EX-HP1	2	H-Pipe	\$465	\$515
EX-RP3	3	Resonator Pipes	\$1,145	\$1,245
EX-MU3	7	Muffler	\$675	\$675
EX-TP6	5	Tailpipes	\$150	\$150
EX-TIP1/2	8	Exhaust Tip	\$325	\$325
EX-MC1	10	Clamps (H-Pipe)	\$28	\$28
EX-MC1	10	Clamps (Muffler)	\$56	\$56
EX-MC5	10	Clamps (Tailpipes)	\$38	\$38
EX-MC6	11	Clamps (Horseshoe)	\$28	\$28
EX-RB1	15	Res Hanger Bolts	\$12	\$12
EX-GAS2	14	Ex Donut Gasket	\$12	\$12
		<b>Total</b>	<b>\$2,934</b>	<b>\$3,084</b>

### 1967 Shelby GT-350 w/289

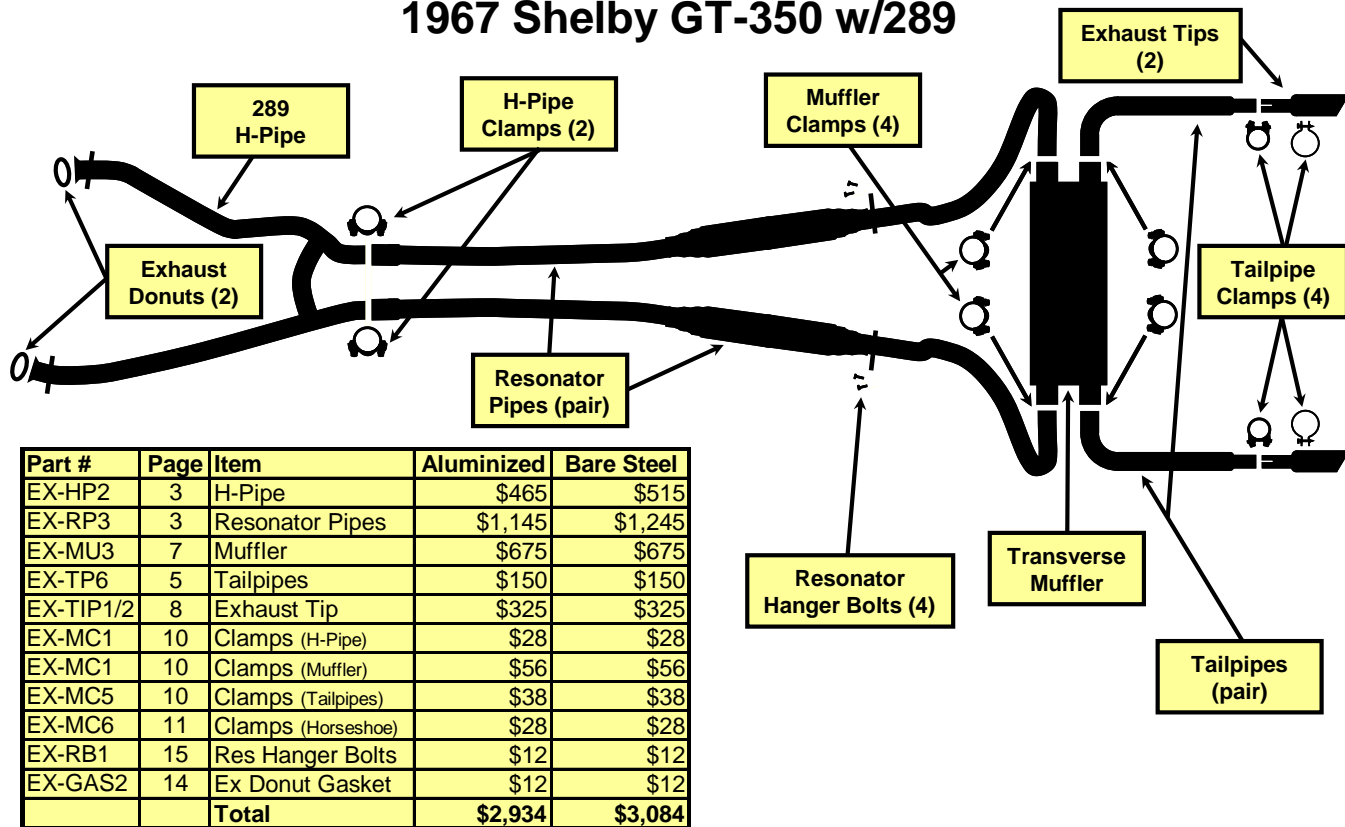

### 1967 Mustang GT w/390

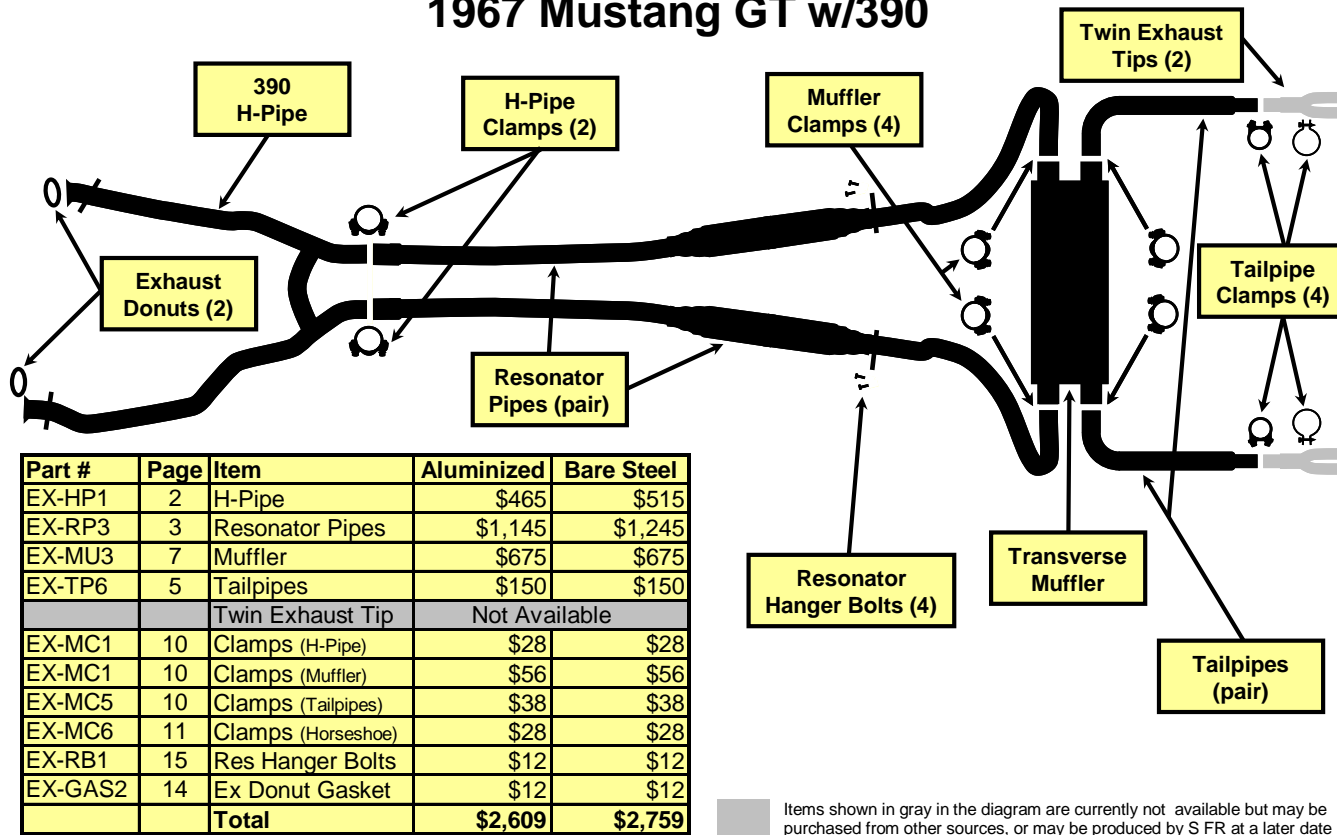

### 1967 Mustang GT w/289

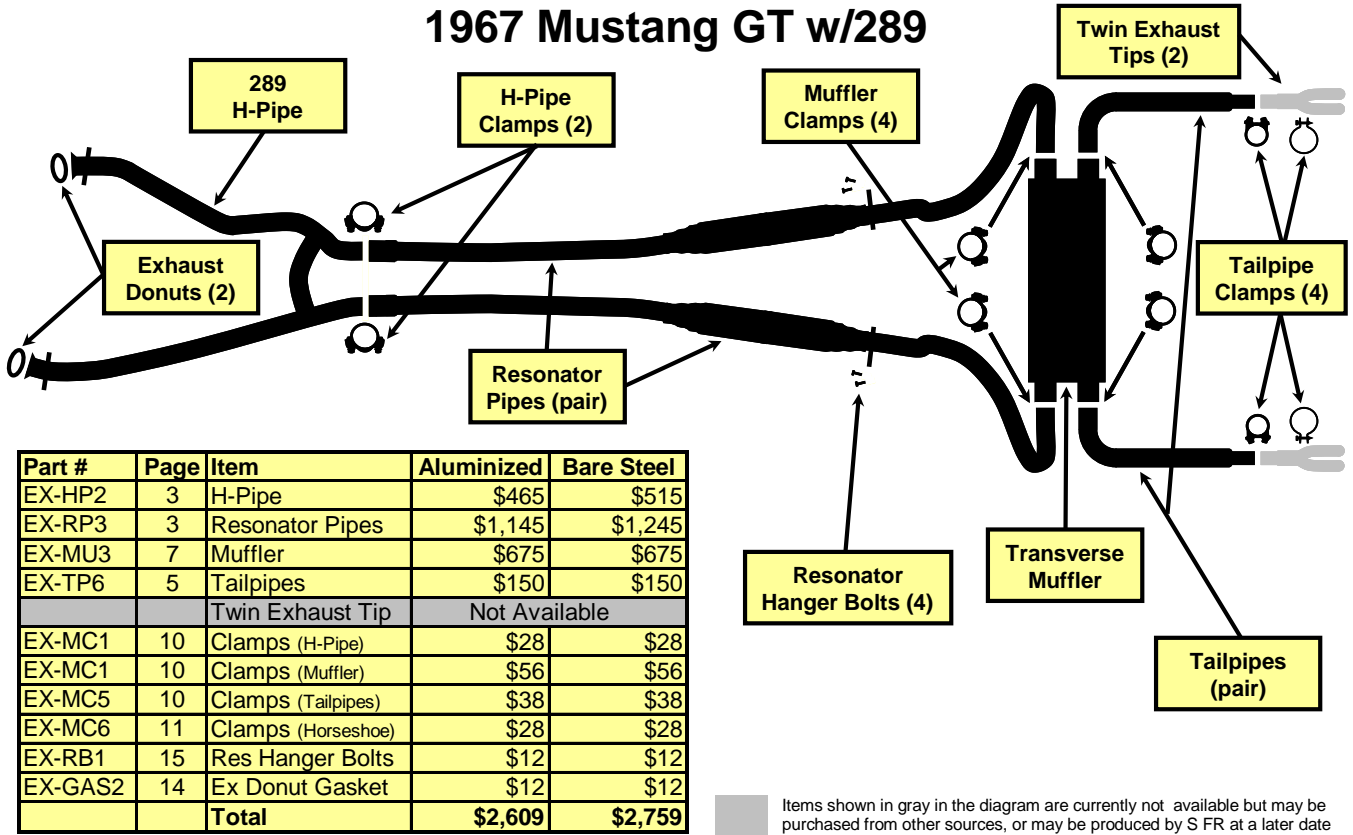

### 1968½ Shelby GT500KR w/428 Cobra Jet

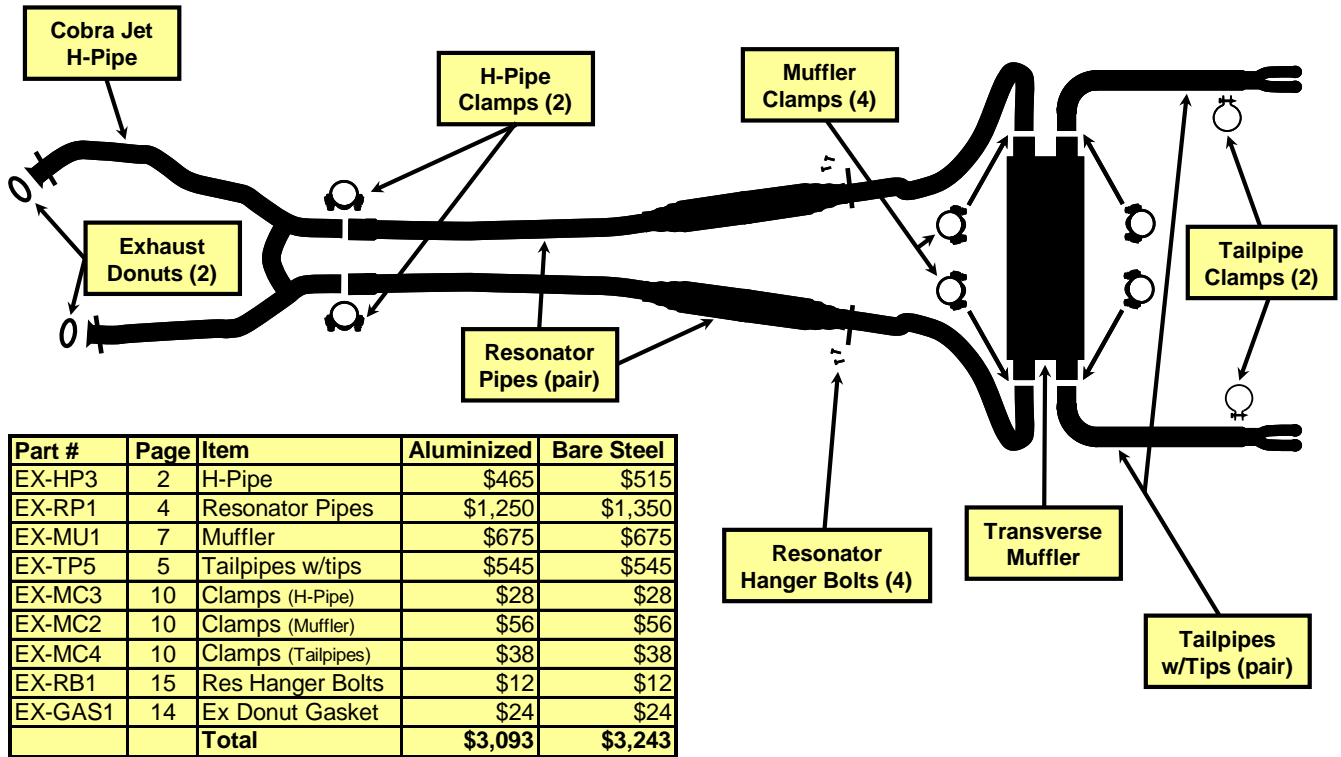

### 1968 Shelby GT-500 w/428 P.I.

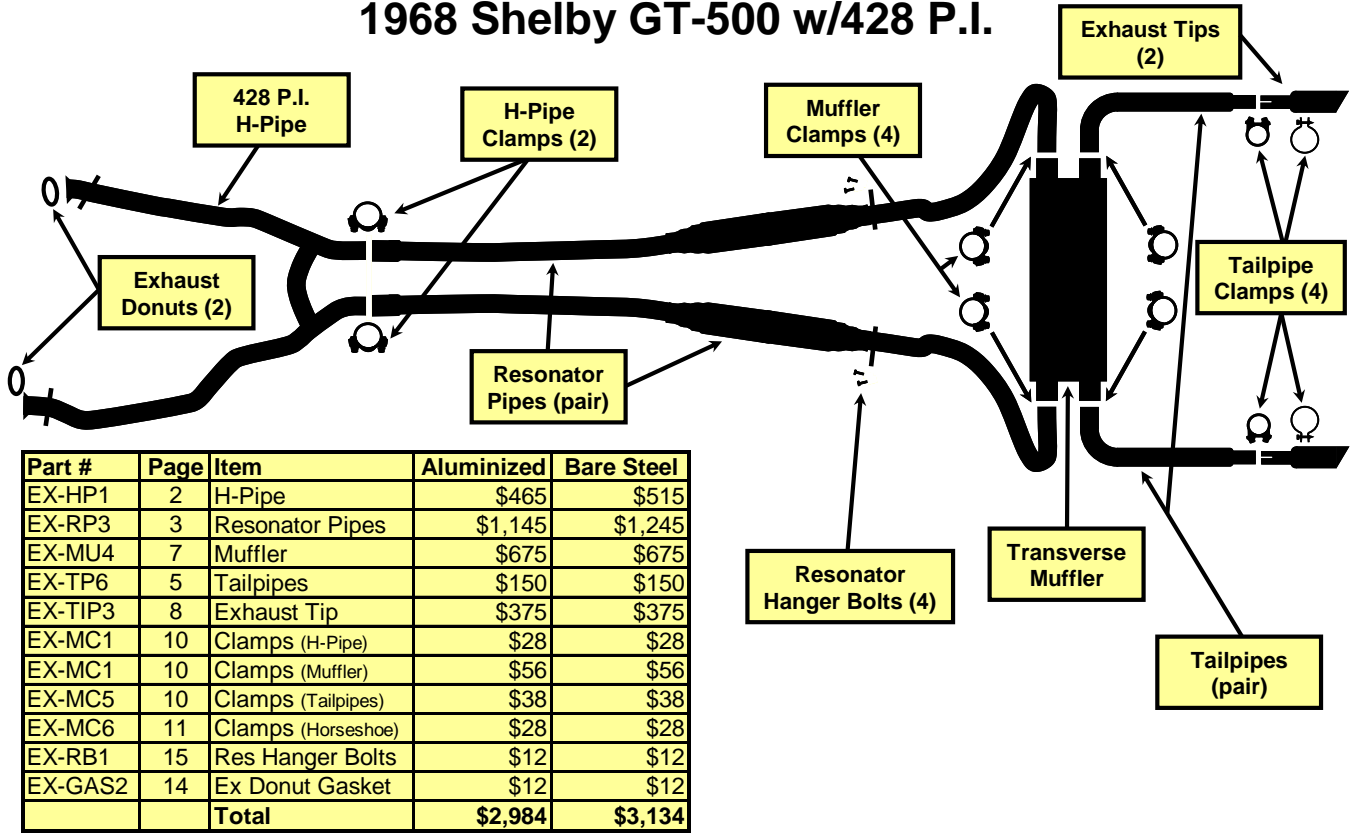

P.a.g.e. S11

### 1968 Shelby GT-350 w/302

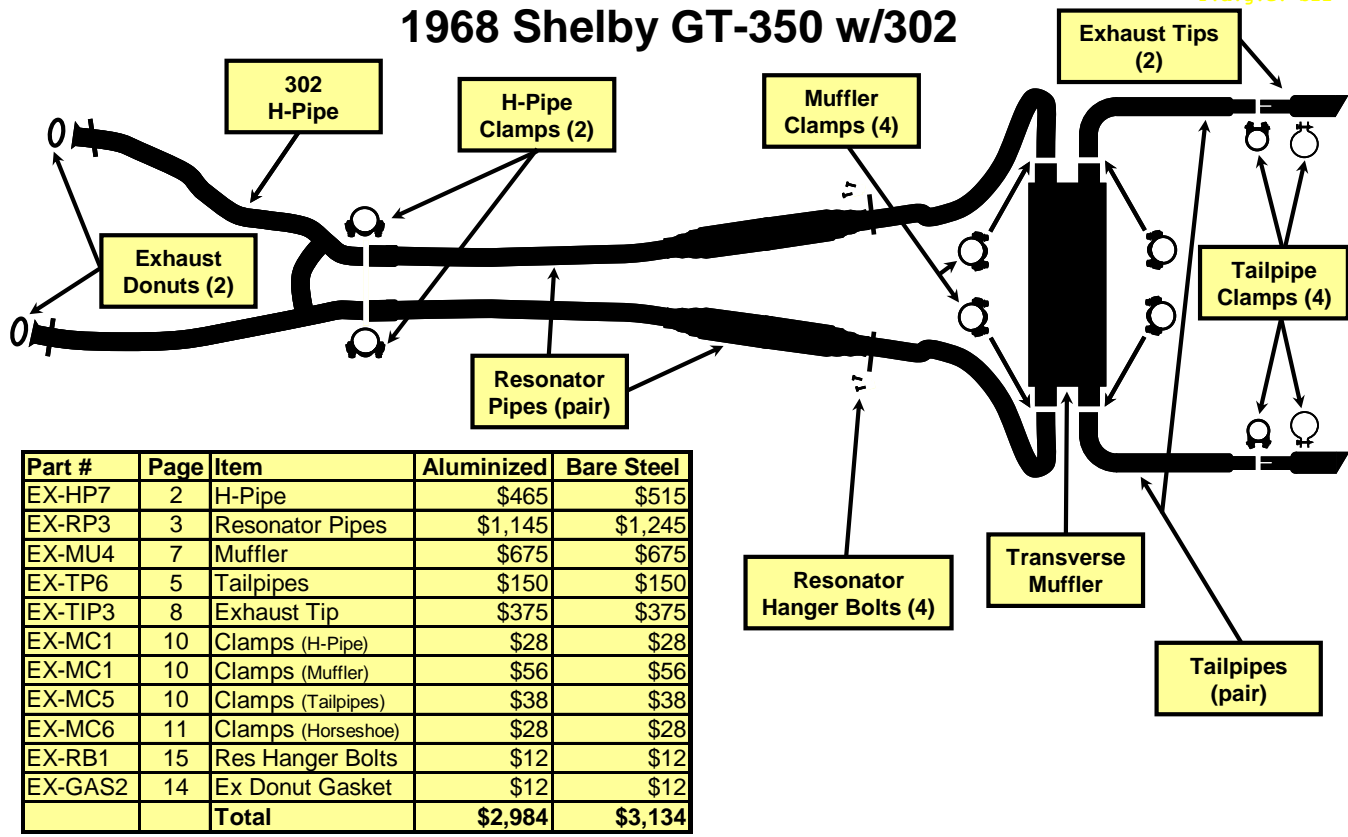

## 1968<sup>1</sup>/<sub>2</sub> Mustang w/428 Cobra Jet

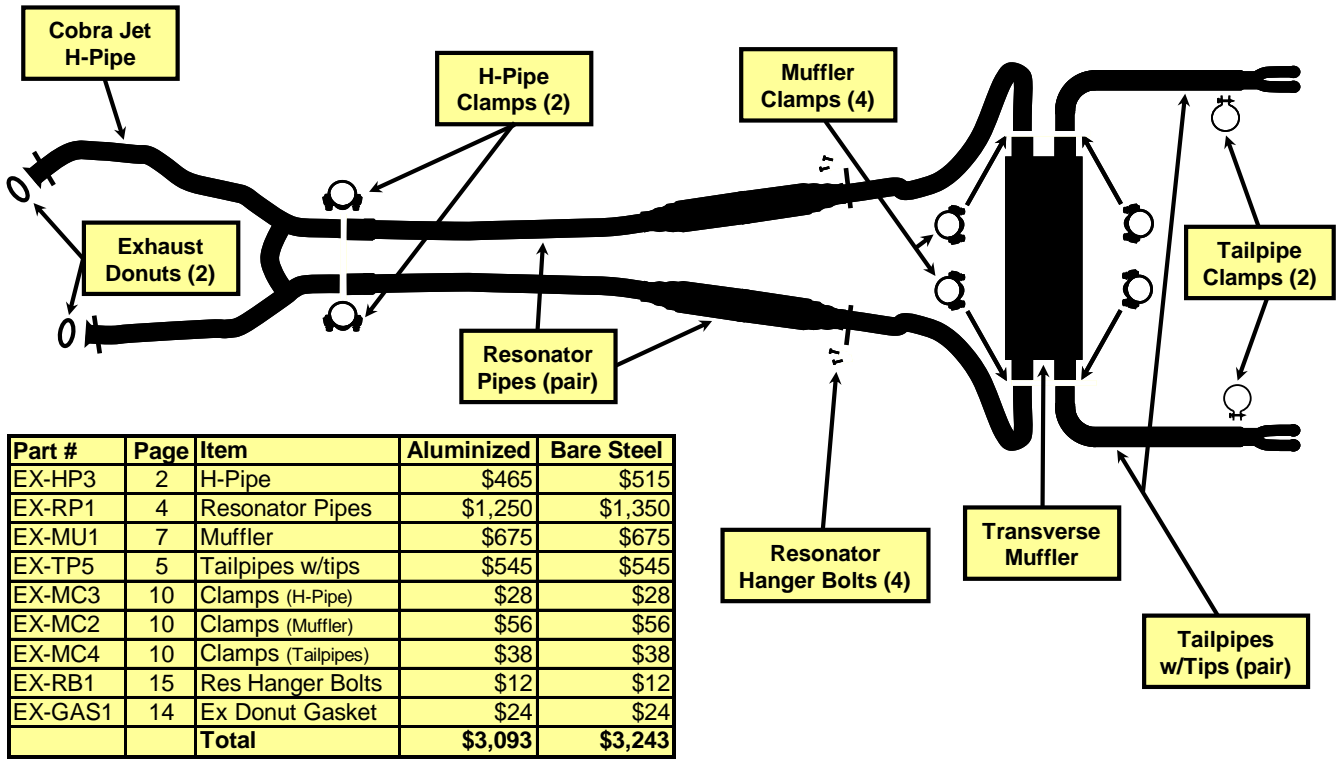

## 1968 Mustang GT w/390

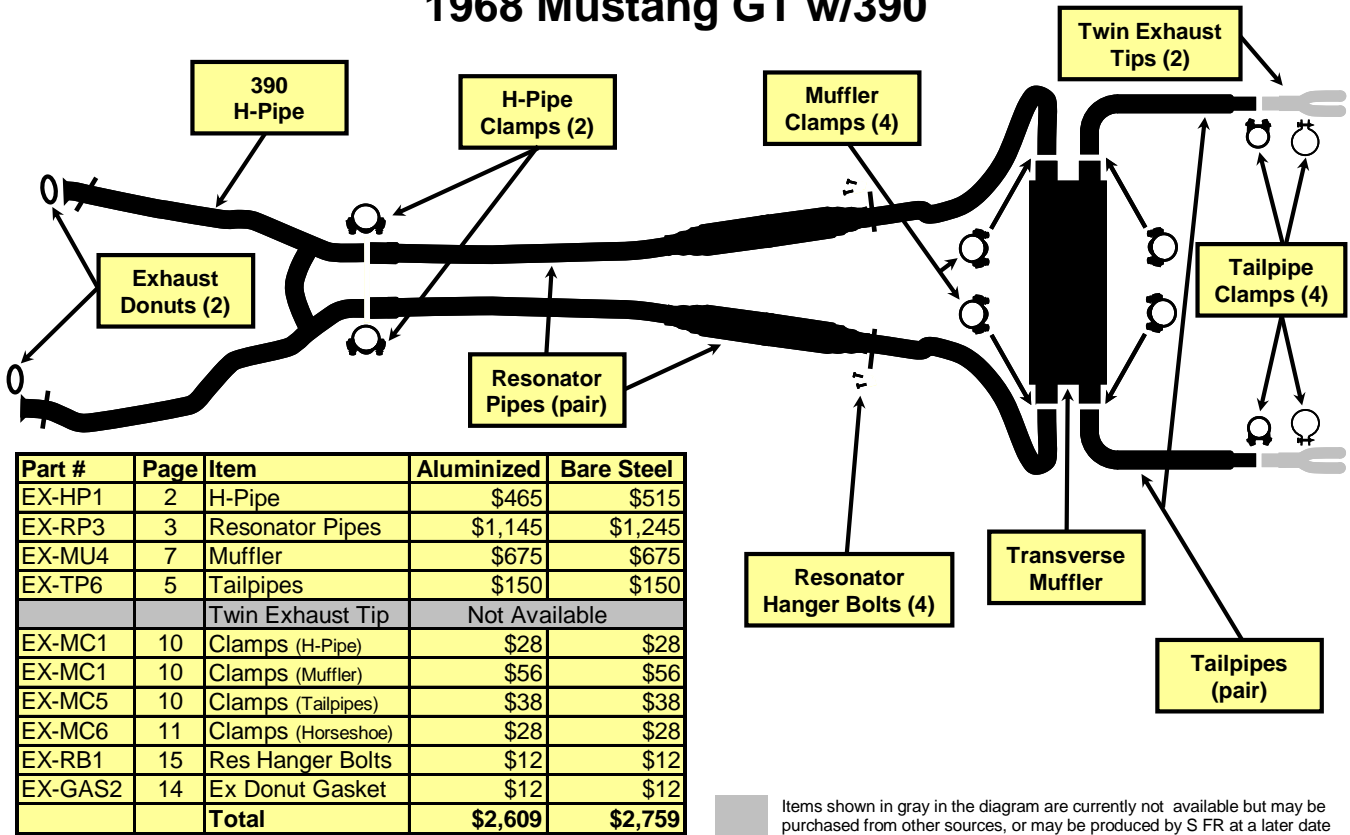

Items shown in gray in the diagram are currently not available but may be purchased from other sources, or may be produced by SFR at a later date

# 1968 Mustang GT w/302

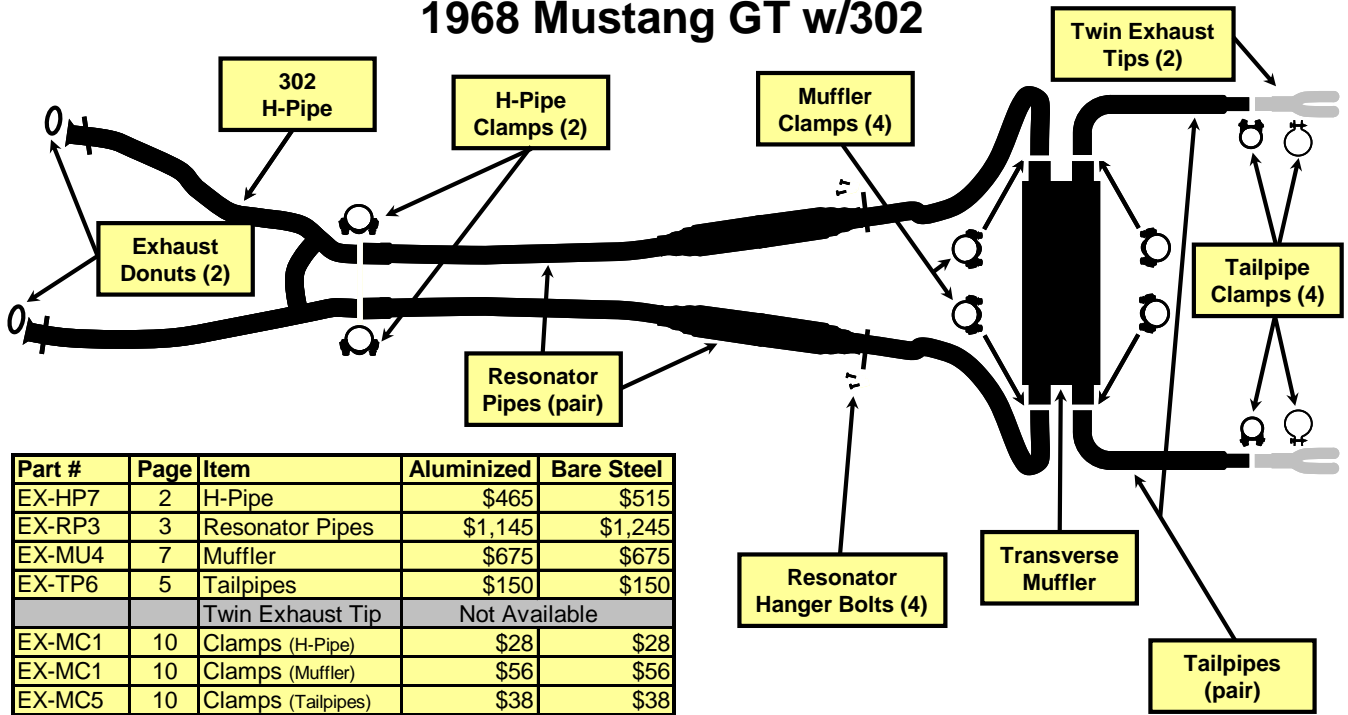

Part #	Page	Item	Aluminized	Bare Steel
EX-HP7	2	H-Pipe	\$465	\$515
EX-RP3	3	Resonator Pipes	\$1,145	\$1,245
EX-MU4	7	Muffler	\$675	\$675
EX-TP6	5	Tailpipes	\$150	\$150
		Twin Exhaust Tip	Not Available	
EX-MC1	10	Clamps (H-Pipe)	\$28	\$28
EX-MC1	10	Clamps (Muffler)	\$56	\$56
EX-MC5	10	Clamps (Tailpipes)	\$38	\$38
EX-MC6	11	Clamps (Horseshoe)	\$28	\$28
EX-RB1	15	Res Hanger Bolts	\$12	\$12
EX-GAS2	14	Ex Donut Gasket	\$12	\$12
		<b>Total</b>	<b>\$2,609</b>	<b>\$2,759</b>

Items shown in gray in the diagram are currently not available but may be purchased from other sources, or may be produced by SFR at a later date

# 1969/1970 Shelby GT-500 w/428 CJ/SCJ

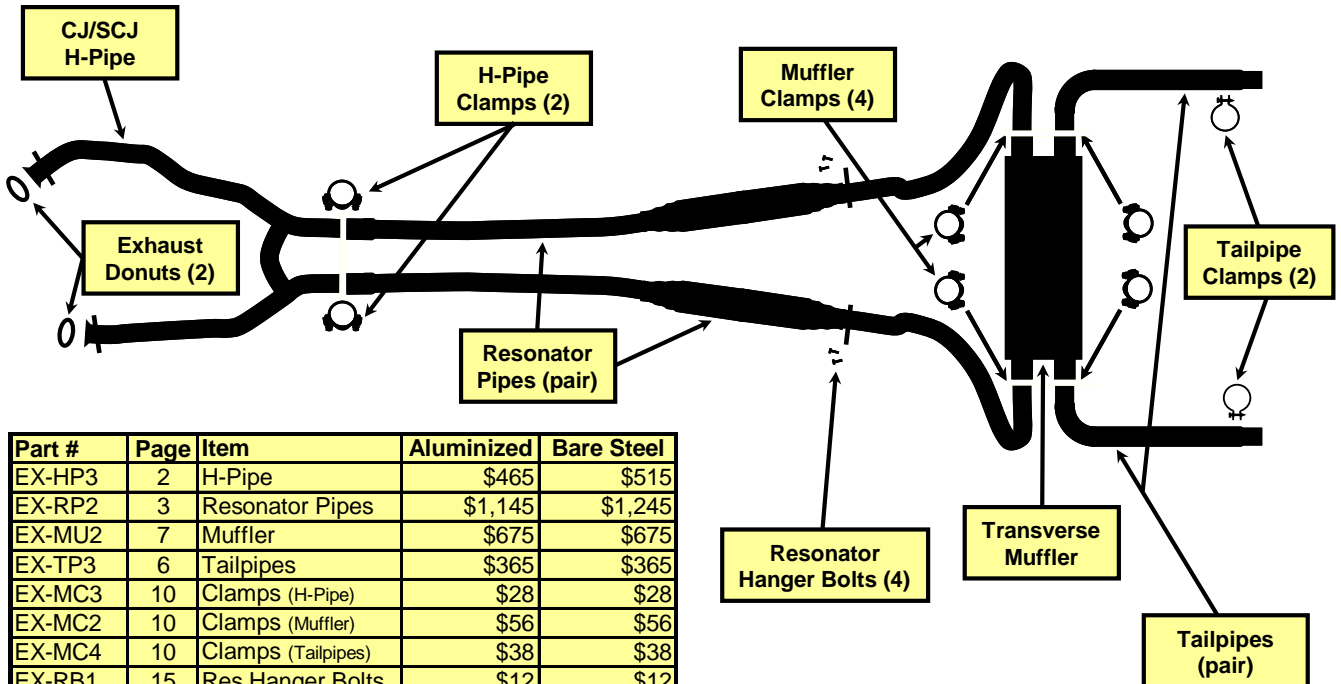

Part #	Page	Item	Aluminized	Bare Steel
EX-HP3	2	H-Pipe	\$465	\$515
EX-RP2	3	Resonator Pipes	\$1,145	\$1,245
EX-MU2	7	Muffler	\$675	\$675
EX-TP3	6	Tailpipes	\$365	\$365
EX-MC3	10	Clamps (H-Pipe)	\$28	\$28
EX-MC2	10	Clamps (Muffler)	\$56	\$56
EX-MC4	10	Clamps (Tailpipes)	\$38	\$38
EX-RB1	15	Res Hanger Bolts	\$12	\$12
EX-GAS1	14	Ex Donut Gasket	\$24	\$24
		<b>Total</b>	<b>\$2,808</b>	<b>\$2,958</b>

# 1969/1970 Shelby GT-350 w/351 Windsor

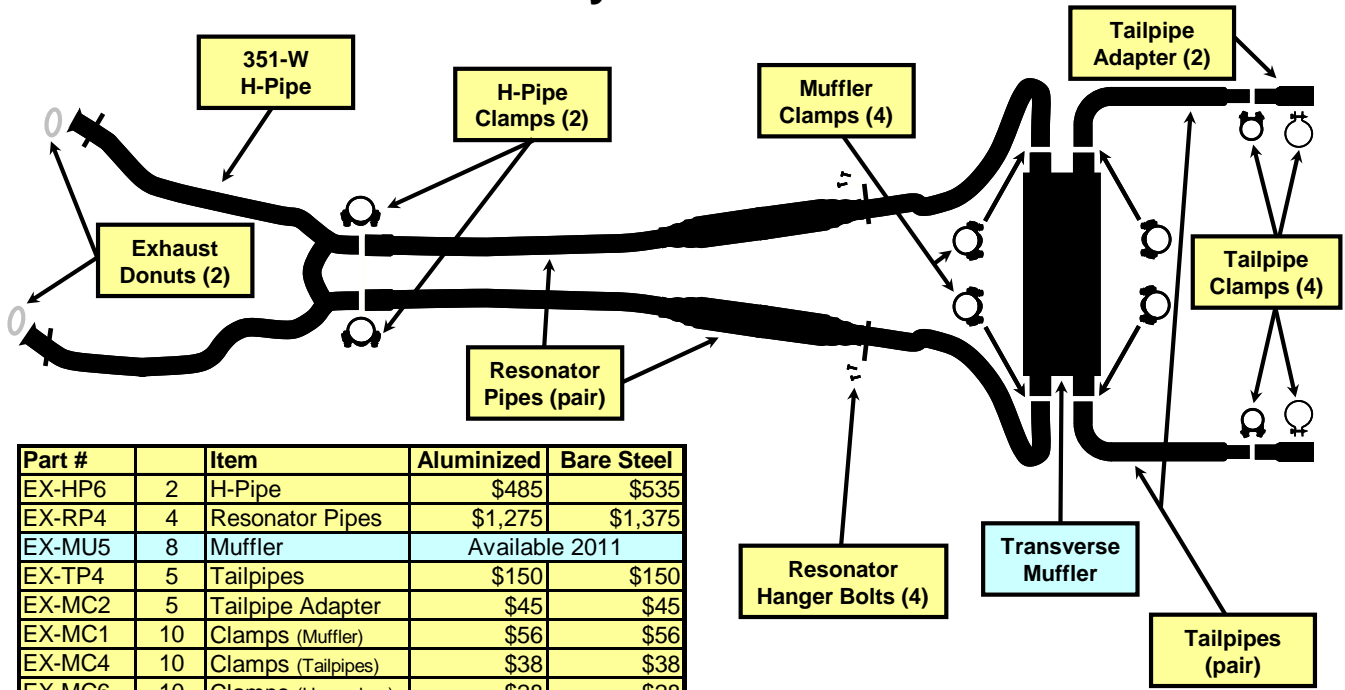

Part #	Item	Aluminized	Bare Steel
EX-HP6	2 H-Pipe	\$485	\$535
EX-RP4	4 Resonator Pipes	\$1,275	\$1,375
EX-MU5	8 Muffler	Available 2011	
EX-TP4	5 Tailpipes	\$150	\$150
EX-MC2	5 Tailpipe Adapter	\$45	\$45
EX-MC1	10 Clamps (Muffler)	\$56	\$56
EX-MC4	10 Clamps (Tailpipes)	\$38	\$38
EX-MC6	10 Clamps (Horseshoe)	\$28	\$28
EX-RB1	15 Res Hanger Bolts	\$12	\$12
	Ex Donut Gasket	Not Available	
	<b>Total</b>	<b>\$2,089</b>	<b>\$2,239</b>

In production at time of catalog printing

Items shown in gray in the diagram are currently not available but may be purchased from other sources, or may be produced by SFR at a later date

# 1969 Boss 429 Mustang

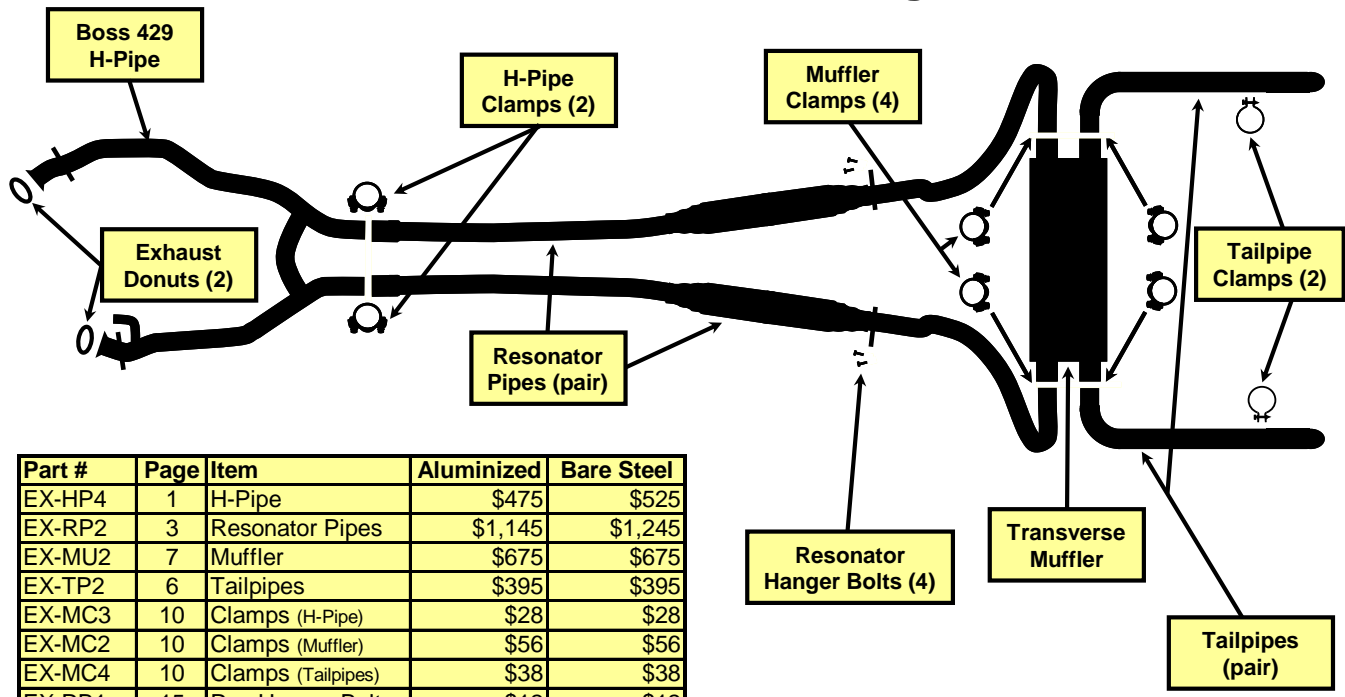

Part #	Page	Item	Aluminized	Bare Steel
EX-HP4	1	H-Pipe	\$475	\$525
EX-RP2	3	Resonator Pipes	\$1,145	\$1,245
EX-MU2	7	Muffler	\$675	\$675
EX-TP2	6	Tailpipes	\$395	\$395
EX-MC3	10	Clamps (H-Pipe)	\$28	\$28
EX-MC2	10	Clamps (Muffler)	\$56	\$56
EX-MC4	10	Clamps (Tailpipes)	\$38	\$38
EX-RB1	15	Res Hanger Bolts	\$12	\$12
EX-GAS1	14	Ex Donut Gasket	\$24	\$24
		<b>Total</b>	<b>\$2,848</b>	<b>\$2,998</b>

### 1969 Boss 302 Mustang

Diagram of the 1969 Boss 302 Mustang exhaust system. Callouts include: Boss 302 H-Pipe, H-Pipe Clamps (2), Resonator Pipes (pair), Muffler Clamps (4), Resonator Hanger Bolts (4), Transverse Muffler, Tailpipe Clamps (2), and Tailpipes (pair).

Part #	Page	Item	Aluminized	Bare Steel
EX-HP5	1	H-Pipe	\$555	\$605
EX-RP2	3	Resonator Pipes	\$1,145	\$1,245
EX-MU2	7	Muffler	\$675	\$675
EX-TP2	6	Tailpipes	\$395	\$395
EX-MC3	10	Clamps (H-Pipe)	\$28	\$28
EX-MC2	10	Clamps (Muffler)	\$56	\$56
EX-MC4	10	Clamps (Tailpipes)	\$38	\$38
EX-RB1	15	Res Hanger Bolts	\$12	\$12
N/A		Ex Donut Gasket	No Donut Used	
		<b>Total</b>	<b>\$2,904</b>	<b>\$3,054</b>

### 1969 Mach I w/428 CJ/SCJ

Diagram of the 1969 Mach I w/428 CJ/SCJ exhaust system. Callouts include: CJ/SCJ H-Pipe, Exhaust Donuts (2), H-Pipe Clamps (2), Resonator Pipes (pair), Muffler Clamps (4), Resonator Hanger Bolts (4), Transverse Muffler, Tailpipe Clamps (2), and Tailpipes w/Tips (pair).

Part #	Page	Item	Aluminized	Bare Steel
EX-HP3	2	H-Pipe	\$465	\$515
EX-RP2	3	Resonator Pipes	\$1,145	\$1,245
EX-MU2	7	Muffler	\$675	\$675
EX-TP1	6	Tailpipes w/tips	\$545	\$545
EX-MC3	10	Clamps (H-Pipe)	\$28	\$28
EX-MC2	10	Clamps (Muffler)	\$56	\$56
EX-MC4	10	Clamps (Tailpipes)	\$38	\$38
EX-RB1	15	Res Hanger Bolts	\$12	\$12
EX-GAS1	14	Ex Donut Gasket	\$24	\$24
		<b>Total</b>	<b>\$2,988</b>	<b>\$3,138</b>

### 1969 Mach I w/351 Windsor

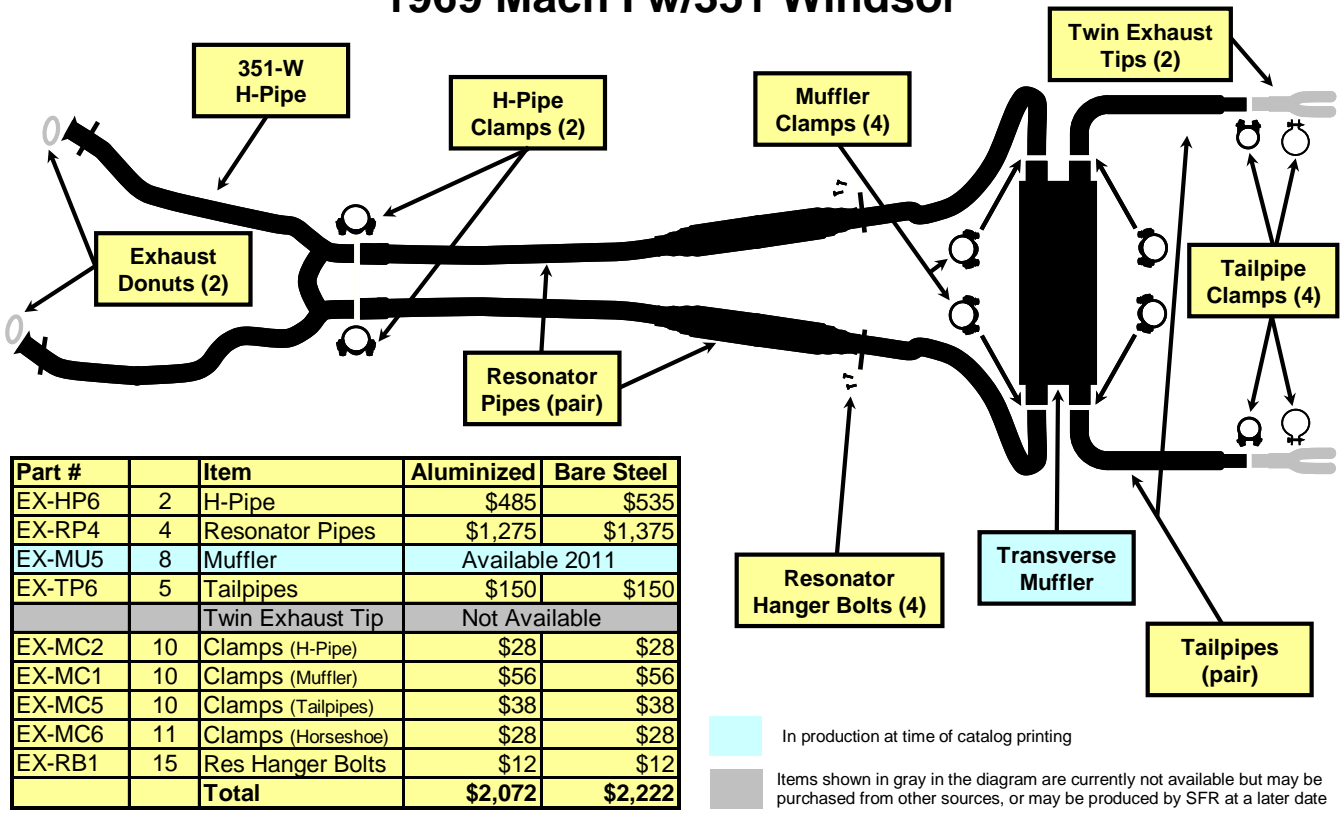

Part #	Item	Aluminized	Bare Steel
EX-HP6	2 H-Pipe	\$485	\$535
EX-RP4	4 Resonator Pipes	\$1,275	\$1,375
EX-MU5	8 Muffler	Available 2011	
EX-TP6	5 Tailpipes	\$150	\$150
	Twin Exhaust Tip	Not Available	
EX-MC2	10 Clamps (H-Pipe)	\$28	\$28
EX-MC1	10 Clamps (Muffler)	\$56	\$56
EX-MC5	10 Clamps (Tailpipes)	\$38	\$38
EX-MC6	11 Clamps (Horseshoe)	\$28	\$28
EX-RB1	15 Res Hanger Bolts	\$12	\$12
	<b>Total</b>	<b>\$2,072</b>	<b>\$2,222</b>

In production at time of catalog printing

Items shown in gray in the diagram are currently not available but may be purchased from other sources, or may be produced by SFR at a later date

### 1969 Mustang GT w/428 CJ/SCJ

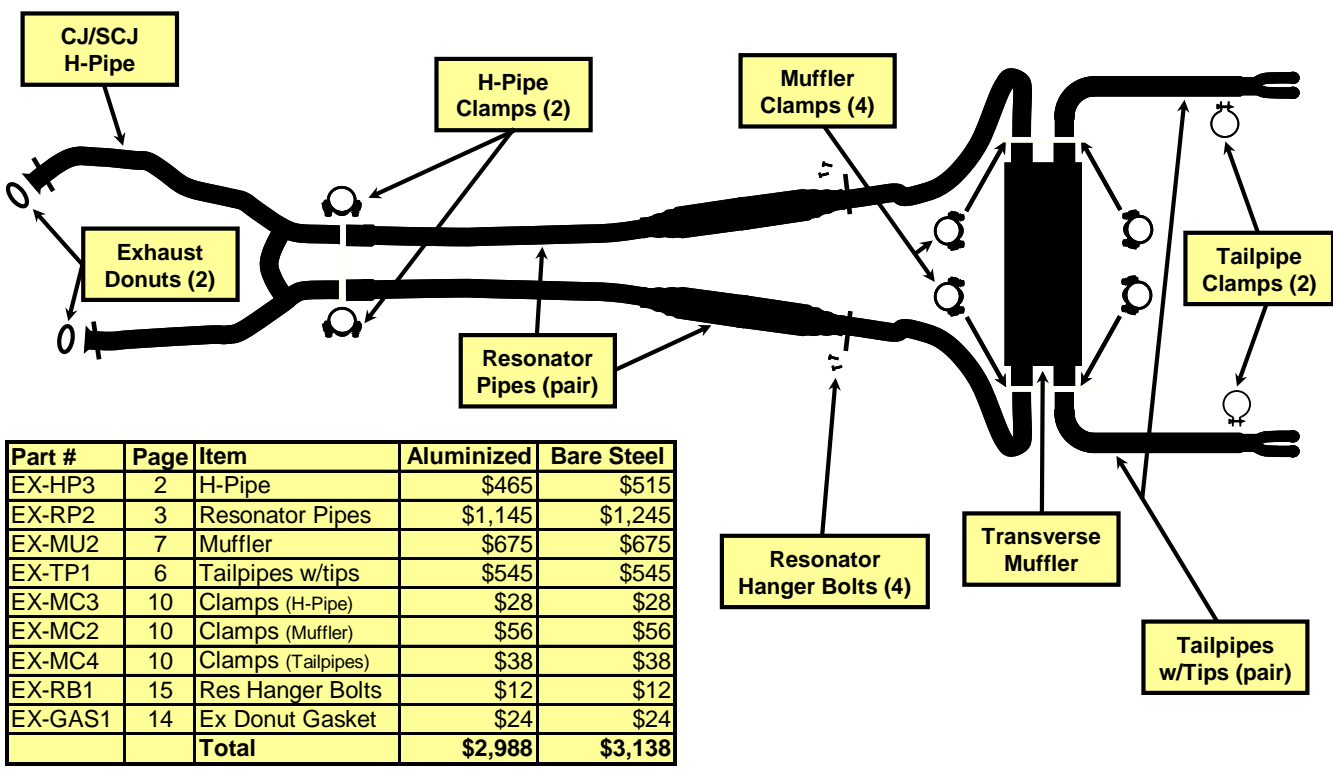

Part #	Page	Item	Aluminized	Bare Steel
EX-HP3	2	H-Pipe	\$465	\$515
EX-RP2	3	Resonator Pipes	\$1,145	\$1,245
EX-MU2	7	Muffler	\$675	\$675
EX-TP1	6	Tailpipes w/tips	\$545	\$545
EX-MC3	10	Clamps (H-Pipe)	\$28	\$28
EX-MC2	10	Clamps (Muffler)	\$56	\$56
EX-MC4	10	Clamps (Tailpipes)	\$38	\$38
EX-RB1	15	Res Hanger Bolts	\$12	\$12
EX-GAS1	14	Ex Donut Gasket	\$24	\$24
		<b>Total</b>	<b>\$2,988</b>	<b>\$3,138</b>

# 1969 Mustang non-GT w/428 CJ/SCJ

Part #	Page	Item	Aluminized	Bare Steel
EX-HP3	2	H-Pipe	\$465	\$515
EX-RP2	3	Resonator Pipes	\$1,145	\$1,245
EX-MU2	7	Muffler	\$675	\$675
EX-TP2	6	Tailpipes	\$395	\$395
EX-MC3	10	Clamps (H-Pipe)	\$28	\$28
EX-MC2	10	Clamps (Muffler)	\$56	\$56
EX-MC4	10	Clamps (Tailpipes)	\$38	\$38
EX-RB1	15	Res Hanger Bolts	\$12	\$12
EX-GAS1	14	Ex Donut Gasket	\$24	\$24
		<b>Total</b>	<b>\$2,838</b>	<b>\$2,988</b>

# 1969 Mustang GT w/351 Windsor

Part #	Page	Item	Aluminized	Bare Steel
EX-HP6	2	H-Pipe	\$485	\$535
EX-RP4	4	Resonator Pipes	\$1,275	\$1,375
EX-MU5	8	Muffler	Available 2011	
EX-TP6	5	Tailpipes	\$150	\$150
		Twin Exhaust Tip	Not Available	
EX-MC2	10	Clamps (H-Pipe)	\$28	\$28
EX-MC1	10	Clamps (Muffler)	\$56	\$56
EX-MC5	10	Clamps (Tailpipes)	\$38	\$38
EX-MC6	11	Clamps (Horseshoe)	\$28	\$28
EX-RB1	15	Res Hanger Bolts	\$12	\$12
		<b>Total</b>	<b>\$2,072</b>	<b>\$2,222</b>

In production at time of catalog printing

Items shown in gray in the diagram are currently not available but may be purchased from other sources, or may be produced by SFR at a later date

## 1970 Boss 429 Mustang

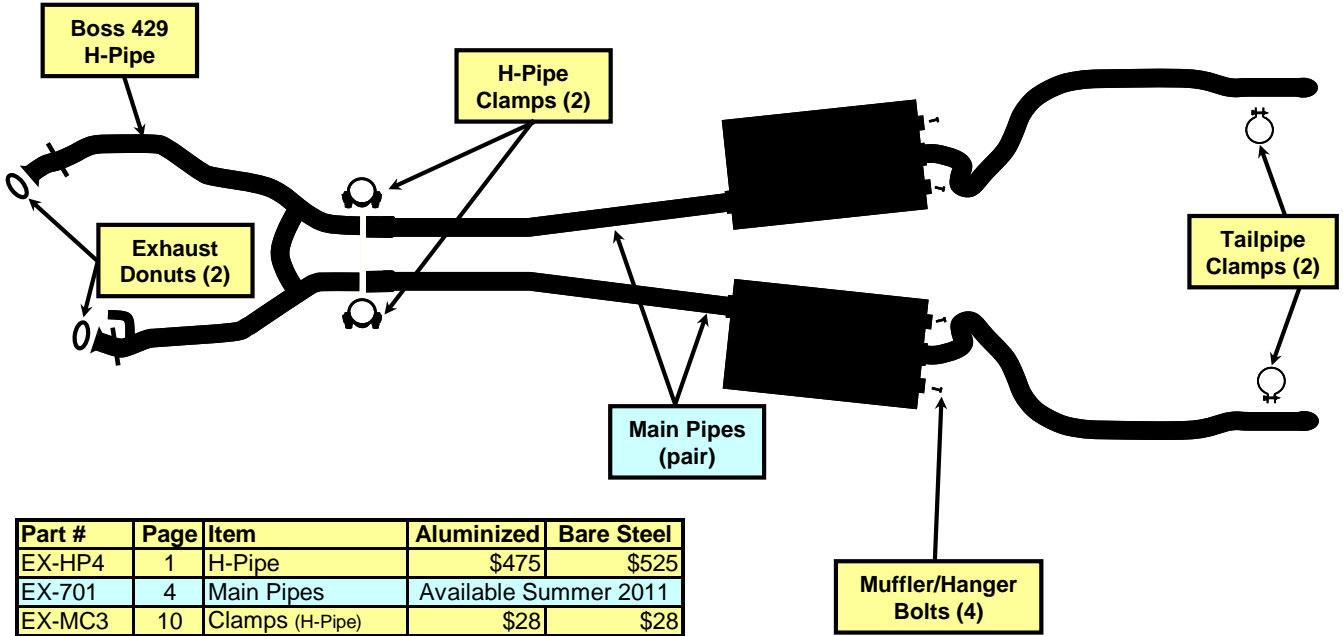

Part #	Page	Item	Aluminized	Bare Steel
EX-HP4	1	H-Pipe	\$475	\$525
EX-701	4	Main Pipes	Available Summer 2011	
EX-MC3	10	Clamps (H-Pipe)	\$28	\$28
EX-MC4	10	Clamps (Tailpipes)	\$38	\$38
EX-GAS1	15	Ex Donut Gasket	\$24	\$24
EX-RB1	14	Muf Hanger Bolts	\$12	\$12
		<b>Total</b>	<b>TBD</b>	<b>TBD</b>

In production at time of catalog printing

## 1970 Boss 302 Mustang

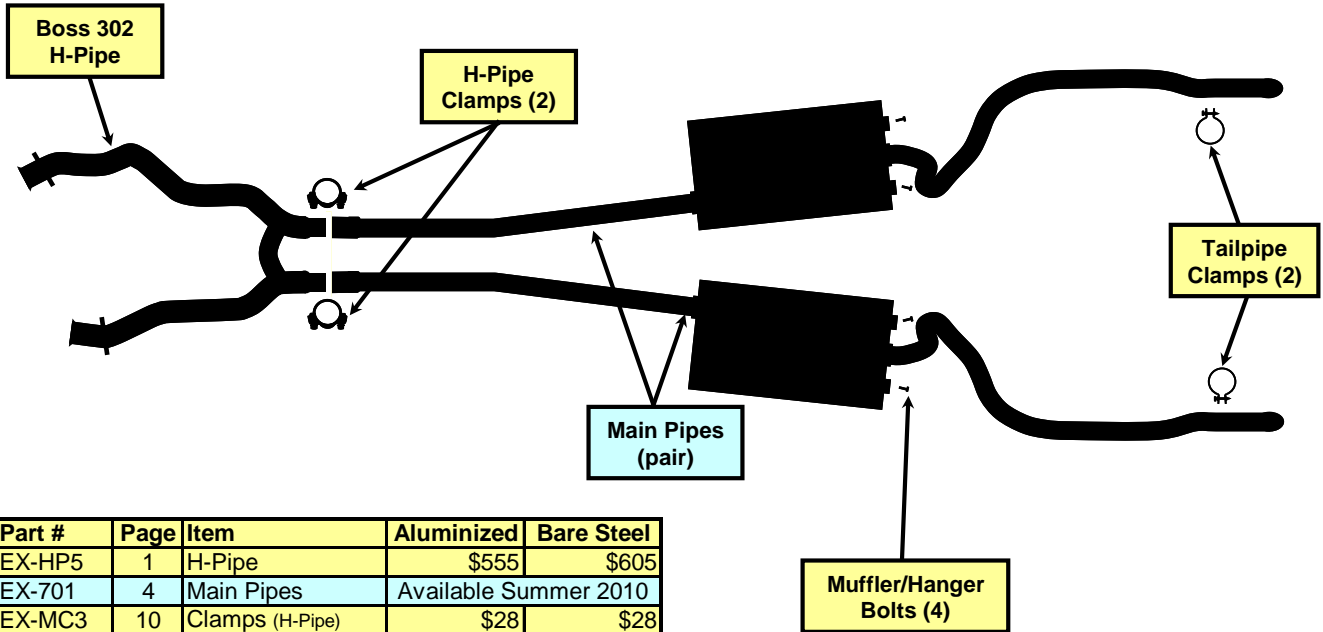

Part #	Page	Item	Aluminized	Bare Steel
EX-HP5	1	H-Pipe	\$555	\$605
EX-701	4	Main Pipes	Available Summer 2010	
EX-MC3	10	Clamps (H-Pipe)	\$28	\$28
EX-MC4	10	Clamps (Tailpipes)	\$38	\$38
N/A		Ex Donut Gasket	No Donut Used	
EX-RB1	14	Muf Hanger Bolts	\$12	\$12
		<b>Total</b>	<b>TBD</b>	<b>TBD</b>

In production at time of catalog printing



## Contact Information

### Telephone: (760) 371-1214

I will answer the phone (if available) between 9:00 a.m. and 9:00 p.m. PST every day of the week. If you miss me and get the answering machine, please leave your name, phone number, and a good time to call you (including time zone) and I will call you back when you request.

### Email:

General questions about my products, questions about new or existing orders, or to contact me directly for any reason:

SFReproductions@aol.com (not case sensitive)

### Mailing Address:

Scott Fuller Reproductions  
1763 Felspar Avenue  
Ridgecrest, California 93555

---

---

## Ordering and Shipping Information

### Ordering:

I gladly accept Credit/Debit Cards (MasterCard, VISA, Discover), Cashier's Checks, Money Orders, and Personal Checks (10-days required to clear). You may also pay through PayPal. Just let me know which method you prefer (for PayPal I will send you an invoice to your e-mail address). If you would like to place an order please call Scott Fuller Reproductions at (760) 371-1214, or e-mail us at SFReproductions@aol.com .

### Shipping:

I ship products EVERY DAY (unless I'm out of town). I assume that if you order it NOW, and pay for it NOW, that you also want it NOW!

**Scott Fuller Reproductions  
1763 Felspar Avenue  
Ridgecrest, CA 93555**

**760-371-1214**



Copyright 2011 © by Scott Fuller Reproductions · All Rights Reserved · Printed in the USA

**1.7.6.3 F.e.l.s.p.a.r A.v.e R.i.d.g.e.c.r.e.s.t C.a.l.i.f.o.r.n.i.a 9.3.5.5.5**

2011 Catalog

[www.ScottFullerReproductions.com](http://www.ScottFullerReproductions.com)